



# Hydraulic dock leveler

---

- Our Hydraulic Dock Leveler compensates the height differences between a truck and a loading dock making it easy to perform loading and unloading operations with safety, steadiness and comfort.

# Loading dock leveler



CAPACITY 30,000, 40,000 AND 50,000 LBS	
Measures	Lip
6' x 8'	16", 18" 20", 22"
6' x 7'	
6' x 6'	
7' x 8'	
7' x 7'	
7' x 6'	
8' x 8'	
8' x 7'	

- When trucking services with different loading heights arrive to your dock, the use of a loading dock leveler is recommended.

▼ Ground

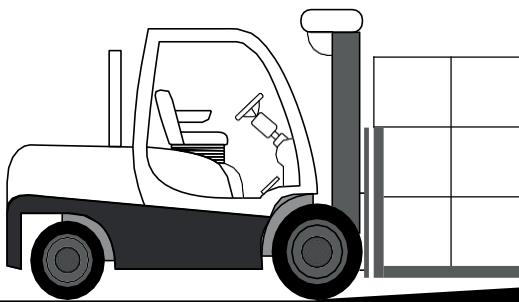

▲ Loading dock leveler

Truck ▼

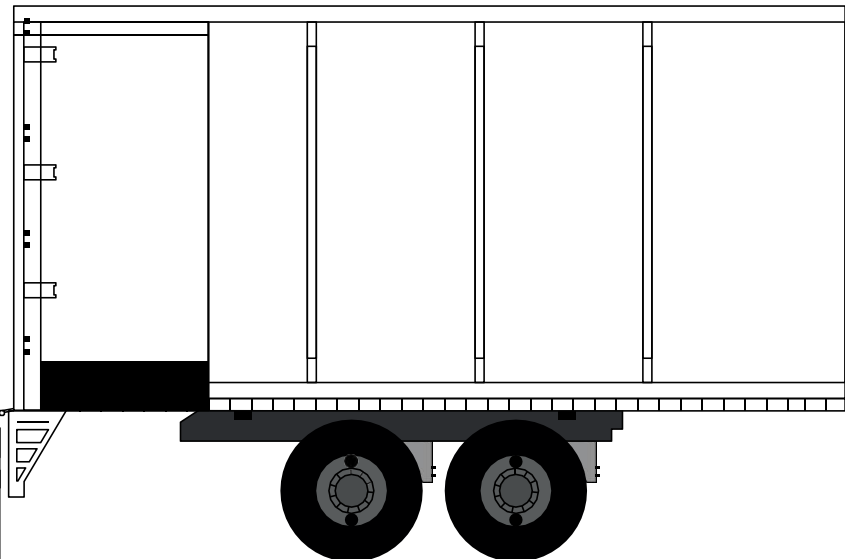

- Optional equipment available up to **50,000 lbs.**

# □ We are manufacturers

Meets **ANSI MH30.1-2022 / ANSI MH30.2-2022** standard.

- For further details on these regulations and the industry standards applicable to this product, please contact:



American National Standards Institute (ANSI)  
1430 Broadway, New York, NY 10018  
+1 212.642.4900  
[www.ansi.org](http://www.ansi.org)



## ▶ SAFETY

# Complete control

Flow regulating valve, limits the ramp free fall, providing a smooth descending process.

Fixed side toe guards, with high visibility safety stripes.

Safety bar to support the lip and ramp, providing better conditions for inspection and maintenance beneath the ramp.

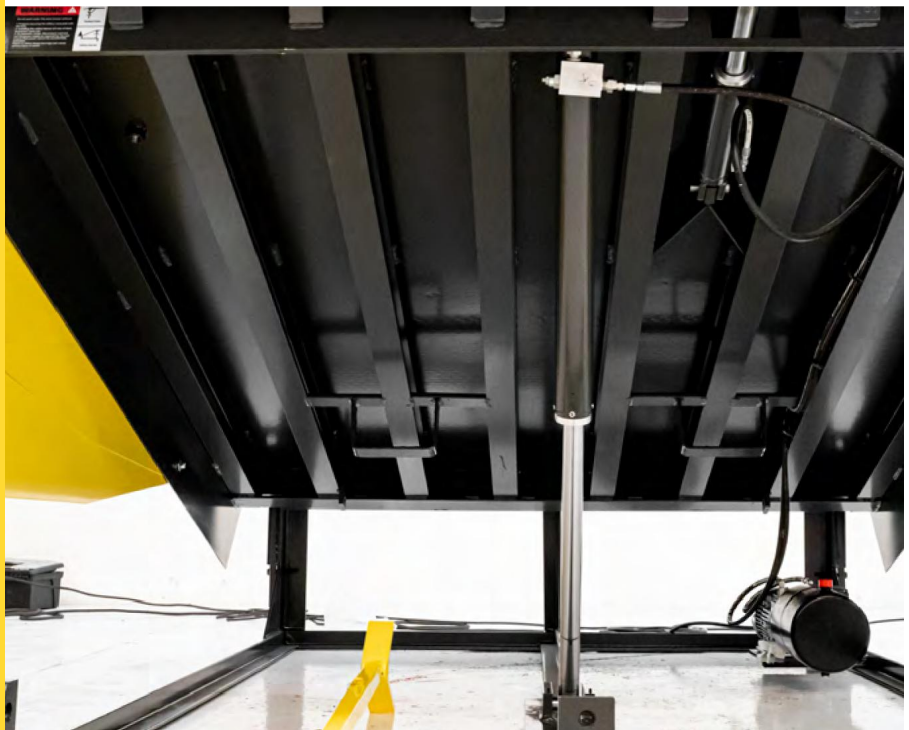



- ▶ The hydraulic loading dock leveler is built over a high quality and reliable structure.
- ▶ Steadiness and maneuvering comfort.



# Description



▶ The bottom is made with a 3x4" PTR and a 6"x4"x 1/4" central HSS.

▶ Founded over a 3/16" thick metal frame.

▶ All of our models include guards.

▶ Anti-skid metal platform of a single 3/16" sheet, with a dynamic load capacity of 30,000 LB and 1/4" in capacities of 40,000 and 50,000 LBS.



hydraulic hoses



▶ **Vonberg** valves to ensure the safe and effective operation of our equipment.

▶ The hydraulic dock leveler is built by a high-quality robust structure to allow reliability in its operation.



▶ **Aeroquip** one-wire braided hose combines high durability, flexibility and pressure tolerance for more efficient, leak-free operations.



# Single Plate

- ▶ THE RAMP PLATE IS ONE-PIECE THE WHOLE DECK, MADE OF A 572-G-50 CARBONO STEEL

SINGLE PLATE



30,000 LBS	40,000 LBS	50,000 LBS
3/16"	1/4"	1/4"

## Lip

LIP IS A CARBONO A 572-G-50 STEEL PLATE

30,000 LBS	40,000 LBS	50,000 LBS
1/2"	5/8"	5/8"



## □ 2 bumpers included



- Dock bumpers, (x2 included), protect your building from impact, providing the space required to activate the Ramp Brake TECNORAMPA®

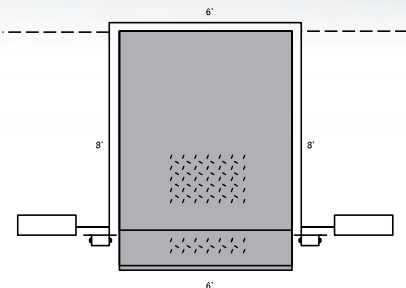

Top view ▲

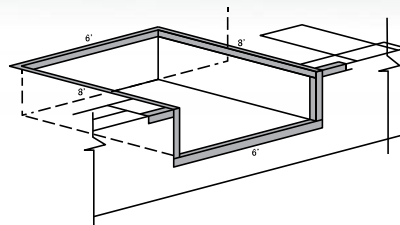

Pit isometric ▲

## Technical details

Nominal dimensions:  
6' x 8' (1829 mm x 2438 mm).

Nominal thickness, (Deck):  
1/4" (6.4mm).

Deck dimensions:  
72" X 99 1/2" (1829 mm x 2527 mm).

Frame:  
30,000 LBS PTR 3"X4".  
40,000 LBS IPS 2"X4".  
50,000 LBS IPR 4"X6".

Leveling:  
12" (304.8 mm) above platform level.  
12" (304.8 mm) above platform level.

Standard Lip:  
16" (406mm).

Lip, nominal thickness:  
5/8".

operation system:  
Hydraulic.

Finish:  
Lead Grey / Yellow.

## ► installation

3' x 3' x 1/4" A-36 Steel Angle.  
Reinforced concrete pit  
(f'c=250 kg/cm<sup>2</sup>).

# POWDER COAT

ELECTROSTATIC

Maximum protection and durability through an advanced electrostatic paint system with a specialised oven for thermal curing.



Excellent impact, abrasion and scratch resistance, validated by ASTM D2794 and ASTM D4060 tests.



Maintains its properties and colour in temperature ranging from -20°C to 200°C, complying with ISO 2813 accelerated ageing stability.

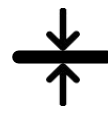

Optimum thickness between 60 and 80 microns, complying with standards such as ISO 2360.



Curing of paint between 180°C and 200°C for 10 to 15 minutes, achieving a thermoset coating validated by adhesion (ISO 2409) and hardness (ASTM D3363) tests.



**2** YEAR WARRANTY

# □ Pit installation requirements

## □ TECHNICAL DETAILS OF THE PIT

### NOMINAL DIMENSIONS:

PIT WIDTH (W):  
74" (1880MM)

PIT LENGTH (L):  
85-1/4" (2165MM)

PIT HEIGHT (H1 AND H2): H1(REAR HEIGHT):  
19-1/2" (495MM) H2(FRONT HEIGHT): 20" (508MM)

PIT MATERIAL:  
CONCRETE WITH A STRENGTH OF 250KG/CM2 WITH AT  
LEAST 15CM (6") THICK

ANGLE OF PIT EDGES: 3" X 3" X 1/4" ANGLE

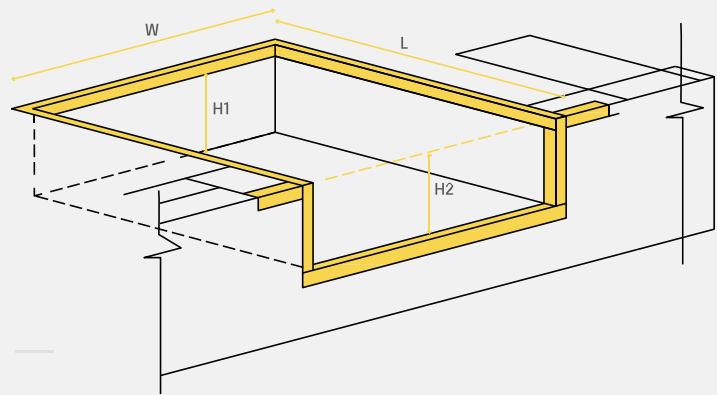

## TECHNICAL DETAILS OF LEVELER

	MODEL OF LEVELER		
	RNH30	RNH40	RNH50
RATED CAPACITY	30,000 LBS	40,000 LBS	50,000 LBS
RATED DIMENSIONS	6'X8' (1829MM X 2438MM)	6'X8' (1829MM X 2438MM)	6'X8' (1829MM X 2438MM)
PLATFORM DIMENSIONS	72" X 83-3/8" (1829MM X 2118MM)	72" X 83-3/8" (1829MM X 2118MM)	72" X 83-3/8" (1829MM X 2118MM)
LEVELING	+/- 12" WITH RESPECT TO PLATFORM LEVEL	+/- 12" WITH RESPECT TO PLATFORM LEVEL	+/- 12" WITH RESPECT TO PLATFORM LEVEL
STANDARD LIP	16",18",20",22"	16",18",20",22"	16",18",20",22"
OPERATION SYSTEM	HYDRAULIC	HYDRAULIC	HYDRAULIC
FINISH	LEAD GREY/YELLOW	LEAD GREY/YELLOW	LEAD GREY/YELLOW



PRERIMETRAL ANGLE 3" X 3" X 1/4" X  
(MATERIAL NOT SUPPLIED BY  
TECNORAMPA)

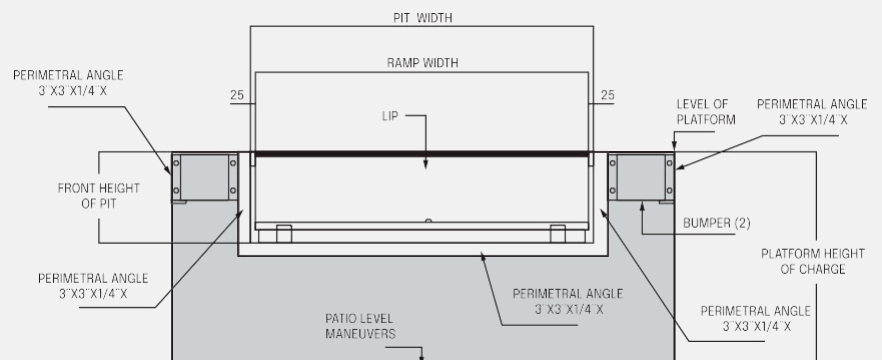

# ► Installation

## ► POINTS TO REVIEW BEFORE UNLOADING AND INSTALLING

### ▣ Pit dimensions

Always use architectural plans when they are available. Check the dimensions of the pit area, to make sure that such a space is suitable and the required space is available.

### ▣ Type of concrete

The ramps must be installed in concrete with a resistance of 250 kg/cm<sup>2</sup> with a minimum of 15cm (6") thickness. If the concrete installed does not comply with at least this specification inform the personnel in charge and do not proceed with the installation of the leveler.

### Defective concrete

- ▣ Visually inspect the area where the ramp will be installed and check for cracks or defects in the concrete. In case of detecting any defect on the concrete, inform the supervisor or personnel in charge of the finding and do not proceed with the installation until the necessary repairs have been made.

## ► INSTALLATION PROCESS

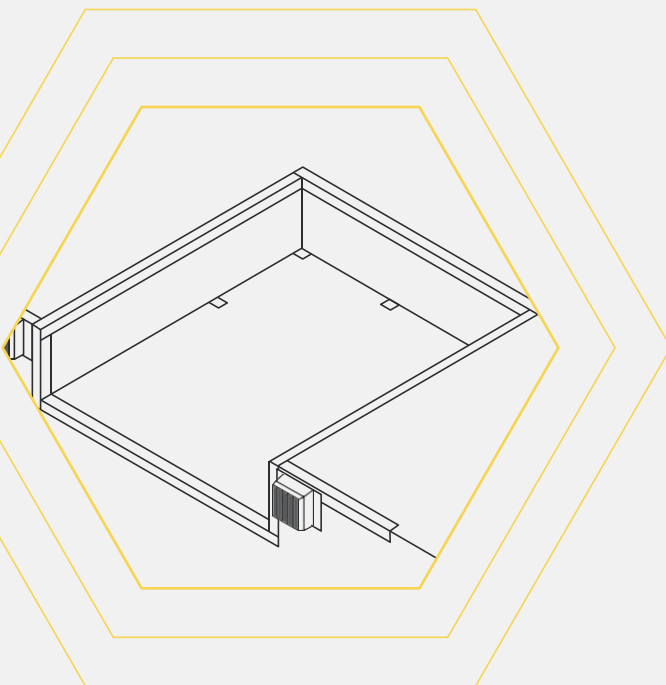

- 1 Unload the ramp and place it near the area where you will try to install it.
- 2 Remove the shipping bands and packing material from the unit.
- 3 Remove the packaging supports.
- 4 Check the quantity of all components with the parts list. If there are missing parts, please contact your ramp supplier.
- 5 Next, measure the depth of the rear corners of the platform pit and do the same with the front corners of the pit.
- 6 Place plate and sheet metal shims to match the height of the rear frame of the grader with the rear edge of the pit as shown.

# ► Installation

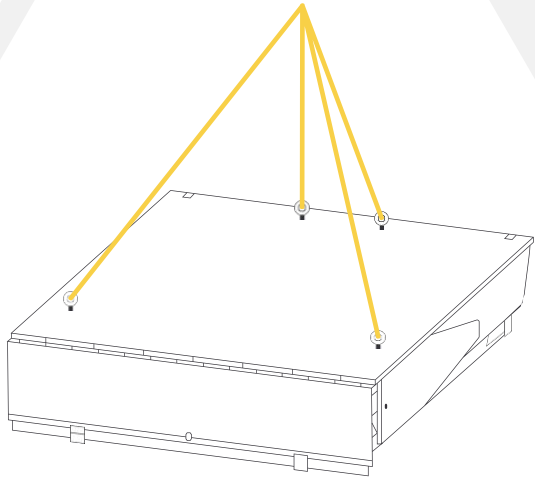

- 7 Using slings or chains for a minimum capacity of 1000 Kg, lift the ramp from the appropriate attachment points as shown below and carefully position it inside the pit. Make sure that the gap between the sides of the grader and the sides of the pit is equal. Also, check that the positioned shims are suitable for leveling the rear edges of the pit and leveler. Add or remove shims as needed.

- 8 Next, release the front lip clamping screw and pull the drive chain slightly to allow the platform to be raised slightly without actuating the lip mechanism.

- 9 Walk on the platform to return the leveler to its stored position making sure that the lip rests correctly on the front supports.

- 10 Check the front height of the platform and adjust the height with shims if required.  
Note: It is recommended that the front of the leveler is always below the platform level.

- 11 Carefully inspect that the rear frame is perfectly aligned with the perimeter angle from the pit. Add or remove shims as needed.

- 12 Also inspect the height and front alignment of the ramp. Add or remove shims as needed.

- 13 Proceed to weld the rear and front frames to secure the leveler in position.  
Use 1/8" 7018 weld to apply evenly spaced weld beads on the contact surface between the rear frame of the leveler and the perimeter angle of the pit. Do the same with the contact surface between the face plate of the leveler base and the front angle of the pit.

- 14 If necessary make the necessary adjustments following the instructions in Section 9.4 HYDRAULIC LEVELER ADJUSTMENTS.

## 8. Form of operation



### WARNING

BEFORE OPERATING THE PLATFORM LEVELER, ALWAYS IMMOBILIZE THE TRUCK WITH A RESTRAINT OR WHEEL CHOCKS.  
DO NOT OPERATE THE PLATFORM LEVELER IF THERE IS SOMEONE STANDING ON IT OR IN FRONT OF IT.  
DO NOT MANUALLY RAISE THE LEVELER LIP.  
ALWAYS KEEP YOUR HANDS AND FEET AWAY FROM MOVING PARTS.  
AFTER SERVICING THE LEVELER, ALWAYS RETURN IT TO ITS SAFE POSITION AT THE PLATFORM LEVEL, WITH THE LIP HELD IN THE CORRESPONDING LOCKS.  
DO NOT DRIVE ON THE LEVELER UNLESS THE EDGE IS FIRMLY IN CONTACT WITH THE VEHICLE PLATFORM AND HAS A MINIMUM PROJECTION OF 4" (100 MM) ONTO THE VEHICLE PLATFORM.  
DO NOT OPERATE THE LEVELER ABOVE ITS SET CAPACITY. DO NOT EXCEED 6.5 MPH WHEN DRIVING ON THE LEVELER.  
DO NOT DRIVE OVER THE EDGES OF THE LEVELER AND/OR THE PLATFORM BUMPERS (THE BUMPERS ARE NOT STRUCTURAL).



### BUTTON FUNCTION

The 'UP' button activates the dock leveler hydraulics when held down.

#### 8.1 CONTROL INDEPENDENT

The control is designed for single ramp operation, using a single button "UP" system with constant hydraulic pressure.

#### 8.2 LEVELER LIFTING

1.

Before operating the platform leveler, immobilize the truck with a restraint or wedges on the wheels

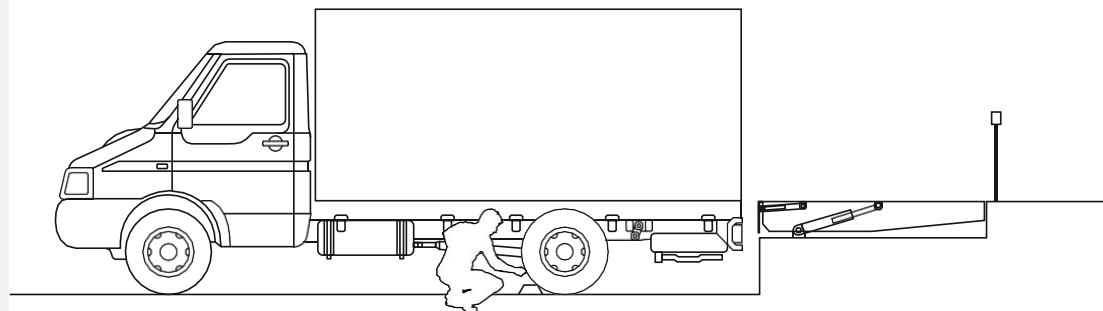

2.

To raise the leveler, activate the leveler by pressing and holding the **UP** button until the leveler is fully raised and the lip is fully extended.

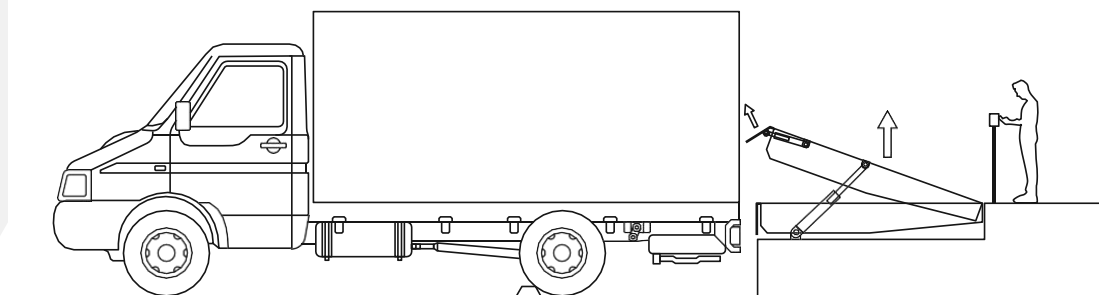

3.

When the lip is fully extended, release the LIFT button. The leveler will automatically lower to the truck/trailer bed.

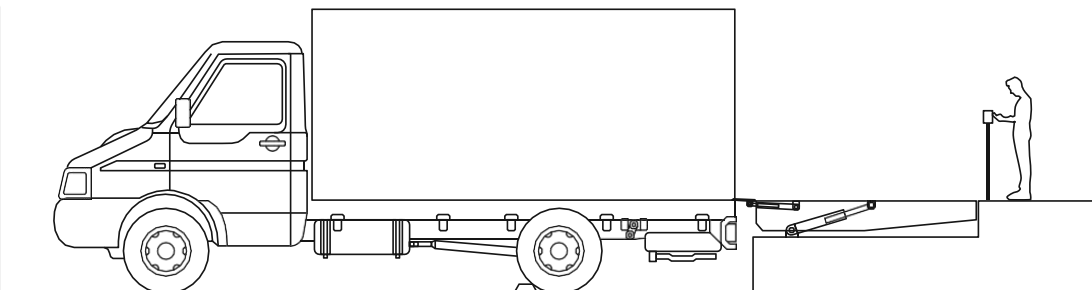

## WARNING

IF THE LIP DOES NOT EXTEND FULLY, DO NOT ATTEMPT TO RAISE IT MANUALLY. BRING THE LEVELER BACK TO PLATFORM LEVEL AND TRY AGAIN. IF THE LIP DOES NOT EXTEND FULLY, THE PLATFORM LEVELER NEEDS MAINTENANCE OR ADJUSTMENT. NOTIFY YOUR SUPERVISOR. DO NOT USE THE LEVELER UNTIL IT IS REPAIRED. FAILURE TO DO SO COULD RESULT IN SERIOUS OR FATAL INJURY.

### ▶ PLACE LEVELER IN ITS RESTING POSITION

1.

To store the leveler, press and hold the **UP** button until the leveler is approximately 6 inches above the level of the platform and the lip is fully retracted.

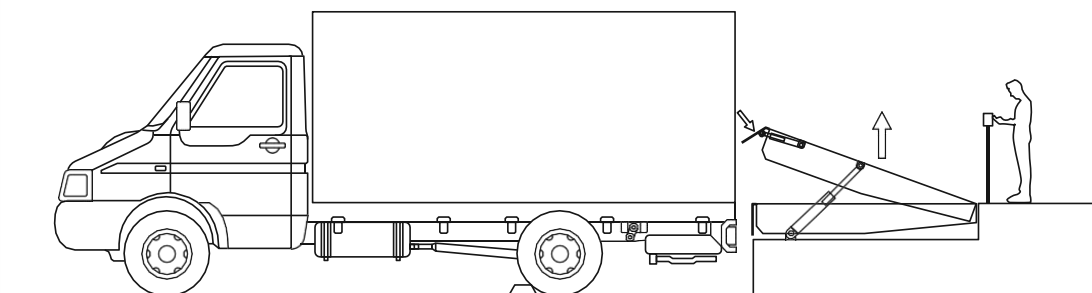

2.

Release the **UP** button. The leveler will lower to platform's level with the edge resting on the lip supports.

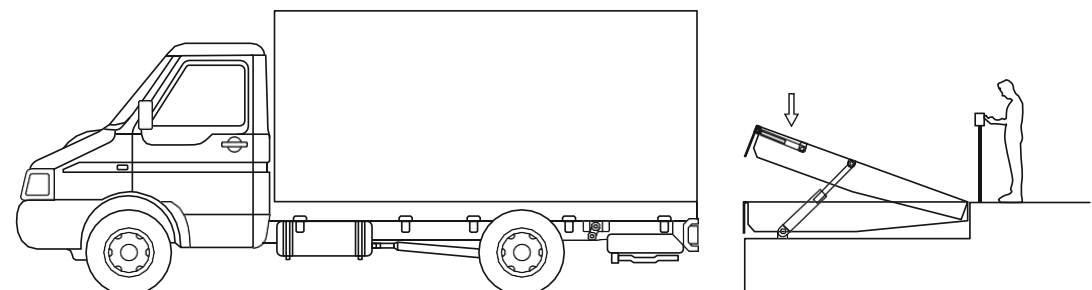

## WARNING

IF THE LIP IS ON THE EDGE OF THE TRUCK/TRAILER AND THE TRUCK PULLS OUT, THE LEVELER WILL MOVE TO ITS LOWEST POSITION AND THE LIP WILL BEGIN TO LOWER.

# □ Hydraulic Lip Valve

## ▶ ADJUSTMENT PROCESS

1. The lip should be extended until the ramp reaches its maximum lifting position.
2. In the event that the lip begins to deploy before the ramp rises to its maximum position, follow the procedure below.

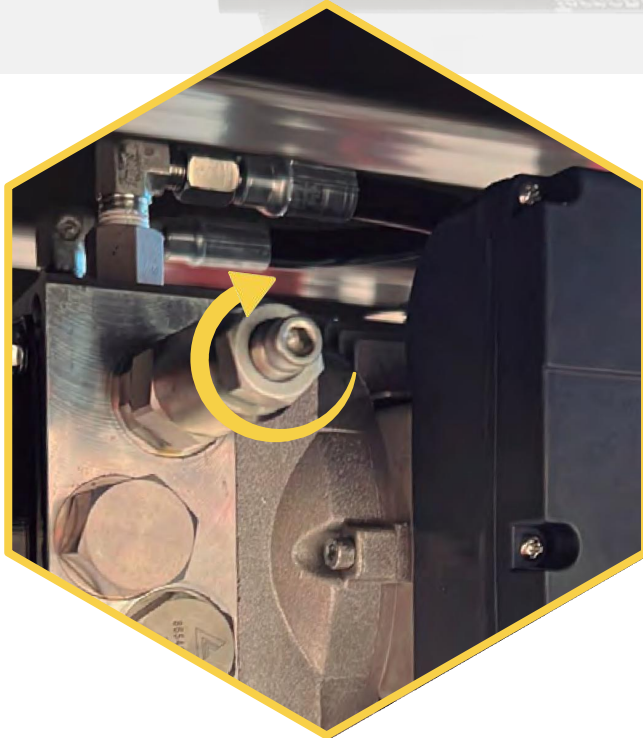

I.- Locate the motor under the ramp, on the right side you can locate the valves.

II.- Turn the valve clockwise, rotate in 180° rounds, until the lip regulates its operation in a normal way.

## ▶ Hydraulic Unit

**BUCHER**  
hydraulics



# □ ft. Maintenance of the equipment



## DANGER

Before installation/maintenance/adjustment, place suitable barriers in order to prevent unauthorized personnel and vehicle traffic from entering the work area.



## DANGER

Before carrying out any adjustment work, place the maintenance bar into position



## WARNING

All repairs and maintenance work must be performed only by trained and authorized personnel.

### ▶ 9.1 PREVENTIVE MAINTENANCE

Every 10 days of operation check the following points:

- ▶ Check for traces of materials on the lip hinge. Clean it as needed.
- ▶ Check for material debris in the area of the leveler's rear hinge and between the sides and edge angles, in order to ensure proper operation. Clean them as needed.
- ▶ Check the safety baton system in order to make sure it is working properly and has no structural defects, pull the chain and check the operation of the recoil spring.
- ▶ Check the operation of the foot guards to make sure that they are not deformed or jammed when the leveler is used.
- ▶ Check that the bolts have their cotter pin in place. Do not operate the ramp if any of the bolts do not have their insurance. Replace them if necessary.
- ▶ Check that the platform bumpers are present.

Every three months or every 250 hours of operation:

- ▶ Clean the inside of the pit area.
- ▶ Check everything for the proper operation of the leveler.
- ▶ Inspect the following items for damage/abnormal wear:
  - Check welding for flaws or fatigue. Pay attention to hinges, top plate beams and front hinge bar.
  - Cylinder bolts and mounting holes.
  - Lip and platform hinge bolts.
  - Check side guards for free movement.
  - Inspect hoses, cylinders, hydraulic connections and the power unit.
  - Inspect control box and conduit for damage.
  - Check if the pusher trolley assemblies and its rollers are damaged.
- ▶ Check all labels and warning signs. Replace as necessary.
- ▶ Check platform bumpers. If they are worn or missing, replace them.
- ▶ Lubricate the following areas:
  - a. Lip hinges through installed grease fittings (Maintenance stick in position to perform this operation). Do not over grease. Stop greasing when oil begins to flow off the ends of the hinge tube. Wipe off excess grease with a cloth.
  - b. Platform hinge area (apply oil to the entire length of the platform hinge when the platform is at its maximum level below ground level).
  - c. Lift cylinder to platform frame pin.
  - d. Lift cylinder to base frame pin.
  - e. Lip cylinder to platform frame pin.
  - f. Lip clevis to lip cylinder pin.

## ▫ PREVENTIVE MAINTENANCE

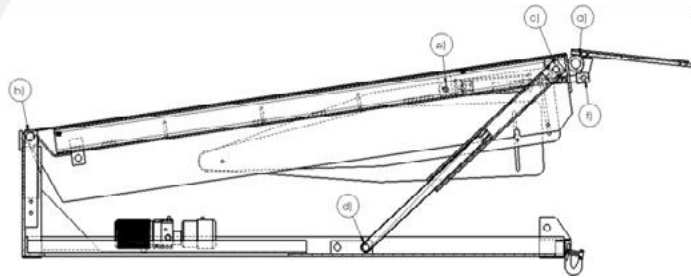

DIAGRAM OF AREAS TO  
BE LUBRICATED

### Semi-Annual Maintenance:

- ▶ Pit cleaning.
- ▶ Re-tightening of hydraulic system connections.
- ▶ Cleaning of hydraulic cylinders and reservoir for fluid evaporation.
- ▶ Inspection of side brushes (if equipped).

### Annual Maintenance:

- ▶ Complete quarterly and semi-annual maintenance.
- ▶ Check fluid level in the reservoir tank:
  1. Place the platform into position with the maintenance sticks.
  2. Turn off all electrical power wired up to the dock leveler.
  3. Remove the breather cap from the reservoir tank.
  4. Measure the fluid level.
  5. Add hydraulic fluid if needed. Use only the recommended hydraulic fluid (ISO 68).
  6. Replace the reservoir tank breather cap.
  7. Turn on the electrical power supply wired up to the dock leveler.
  8. Remove safety poles and return the platform to its stowed position.

# Inventory of parts

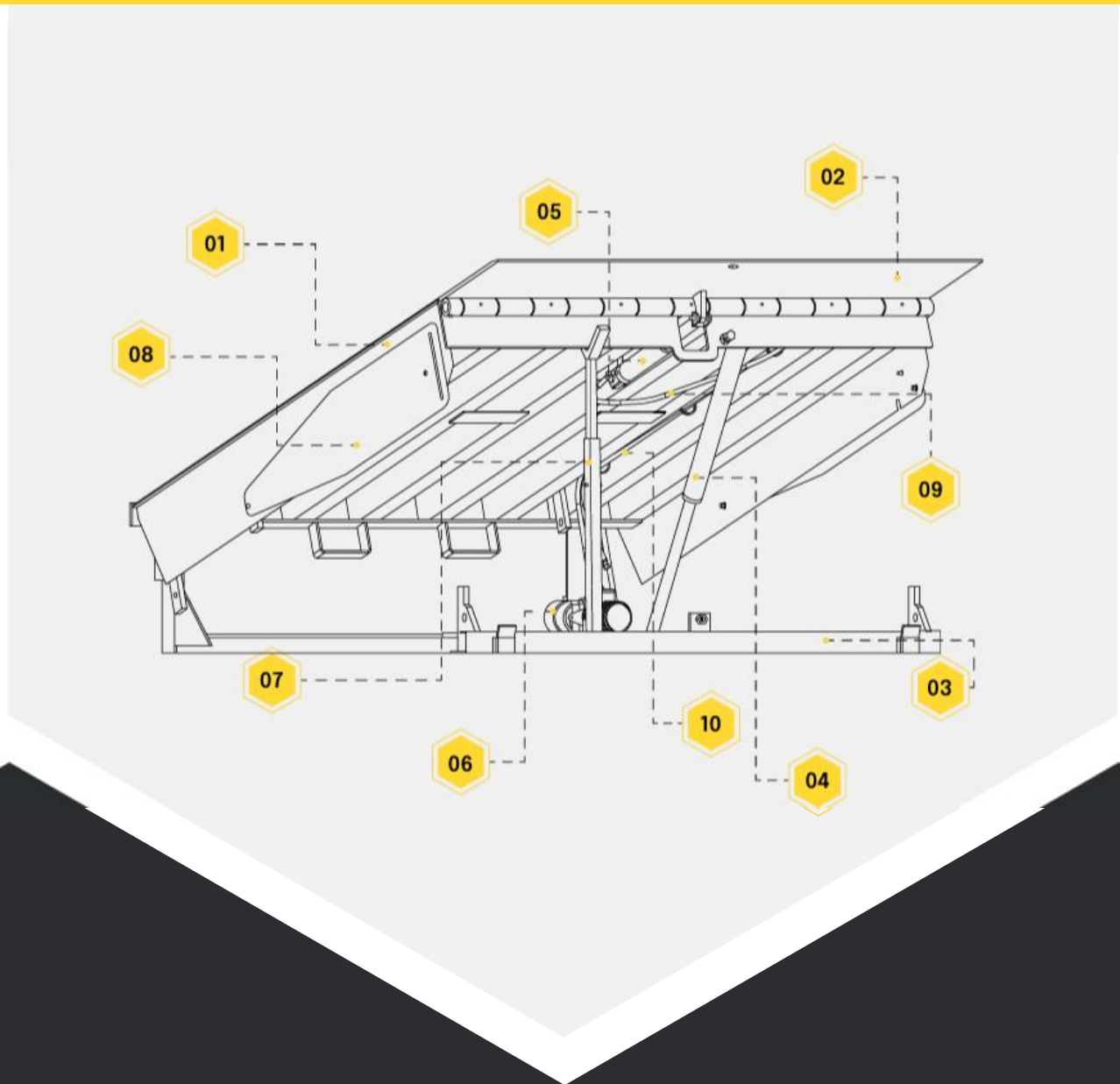

NO.	DESCRIPTION
01-	Hydraulic platform ramp platform
02-	Lip
03-	Base
04-	Platform Cylinder
05-	Lip Cylinder
06-	Hydraulic Unit
07-	Maintenance Bar
08-	Side Protection Guard
09-	Lip Cylinder Hose
10-	Platform Cylinder Hose

› VEHICLE RESTRAINT

# WE ARE MANUFACTURERS›

EXPLORE OUR  
EXPERTISE IN:

# TecnoRampa®



**PARTS**



**ATTENTION**



**SERVICE**

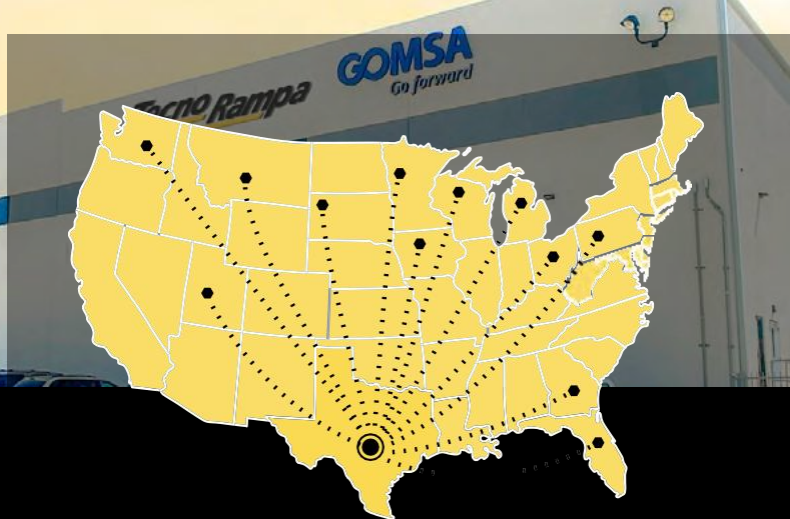

[tecnorampa.us](http://tecnorampa.us)



***TecnoRampa***



N&H ACCESOS INDUSTRIALES

OTE 16A 19, CARLOS HANK GONZALEZ, 56510  
ESTADO DE MÉXICO

55 1306 8592

[hugo.cruz@nyhaccesosindustriales.com](mailto:hugo.cruz@nyhaccesosindustriales.com)