



# Mechanical dock leveler

---

USER MANUAL

# □ table of contents

	Tema	Página
1	SEE SHIPPING NOTICE	2
2	OWNER'S PURCHASE RECORD	2
3	INTRODUCTION	3
3.1	WARRANTY	3
3.2	EXCLUSION OF WARRANTY	3
3.3	OWNER'S LIABILITY	3
4	SAFETY WARNINGS	5
4.1	IDENTIFICATION OF COLORS ON SAFETY SIGNS AND SAFETY MESSAGES	5
5	SAFE PRACTICES	6
6	PIT INSTALLATION REQUIREMENTS	7
7	INSTALLATION	8
7.1	POINTS TO CHECK BEFORE INSTALLATION	8
7.2	INSTALLATION PROCESS	9
8	FORM OF OPERATION	10
8.1	RAISING THE LEVELER	10
8.2	PLACING THE LEVELER IN THE REST POSITION	11
8.3	PLACING THE LEVELER IN THE REST POSITION (MANUAL LIP LOWERING)	12
9	MAINTENANCE OF THE EQUIPMENT	14
9.1	PREVENTIVE MAINTENANCE	14
9.2	CHECKLIST OF INSPECTION PROCEDURES PRIOR TO RAMP OPERATION	15
9.3	TROUBLESHOOTING GUIDE	16
10	MECHANICAL LEVELER ADJUSTMENT	18
10.1	MAINTENANCE BAR	18
10.2	ADJUSTMENT OF MAINSPRING ROD ADJUSTMENT	18
10.3	TENSION SPRING WITH HOOK FOR LIP LOCK	20
10.4	LIP PUSH STICKS	20
10.5	BRAKE SPRING ADJUSTMENT	21
10.6	LIP STOP SCREW ADJUSTMENT	21
10.7	RAMP MEASUREMENTS FOR ADJUSTMENT REFERENCE	22
11	PARTS INVENTORY	23
11.1	MECHANICAL LEVELER PARTS EXPLOSION	24
11.2	MECHANICAL LEVELER PARTS LIST	25
11.3	BRAKE PARTS LIST AND BRAKE EXPLOSION	26
11.4	CARRIAGE EXPLODED VIEW	27
11.5	SPARE PARTS	28
11.6	MECHANICAL PLATFORM RAMP DECAL	29
11.7	VISUAL AID MECHANICAL PLATFORM RAMP DECAL	30

# 1. See shipping notice

---

## CHECK SHIPPING BEFORE INSTALLATION

The Mechanical Platform Dock Leveler has been carefully inspected at the manufacturing plant prior to shipment. To ensure that no damage has occurred during shipment, the dock leveler should be inspected upon receipt for shipping damage and to ensure proper operation. Damage due to shipping damage should be noted on the signed copy of the shipping document. The carrier must be notified of any damage within 48 hours of delivery.

## NOTE

IF ANY DAMAGE IS DETECTED IN THE EQUIPMENT RECEIVED, YOU SHOULD CONTACT THE MANUFACTURER FOR VALIDATION OF THE EQUIPMENT.

# 2. Owner's purchase record

## OWNER'S PURCHASE REGISTRATION

DEALER:

DATE OF SERVICE:

OWNER:

NUMBER OF UNITS:

ORDER NUMBER:

YEAR BUILT:

SERIAL NUMBER:

MODEL:

TECNORAMPA has a complete line of platform levelers, parking ramps, freight elevators and accessories. In accordance with the policy of continuous improvement in its product line, specifications and operating instructions are subject to change/modification without prior notification.

Descriptions and illustrations included in our operating instructions are not binding. Please contact Tecnorampa for the latest product information, or visit our website <https://www.tecnorampa.com.mx/> for the most current product information.

# 3. Introduction

## ▶ 3.1 WARRANTY

Tecnorampa warrants by and for the sole benefit of the original purchaser of the manufactured platform leveler that the Product will be free from defects in materials and workmanship, subject to the following express provisions: Base Warranty: all products are warranted for a base period of 2 years ("Base Warranty Period") from the earlier of the date of installation approved by Tecnorampa or the sixtieth (60th) day after the date of shipment.

Mainspring Warranty: All mainsprings are warranted to cover the cost of replacement parts only for a period of (2) years. Parts and Assembly Warranty:

All spare or replacement parts are warranted to cover the cost of replacement parts and freight only for forty-five (45) days from the date of shipment.

## ▶ 3.2 WARRANTY DISCLAIMER

The foregoing warranties apply in lieu of any other warranties, whether express or implied, including, but not limited to, any implied warranty or merchantability for a particular purpose.

This Limited Warranty shall be null and void (i) if a Product is altered or modified from its original condition as installed or delivered at or from the factory, (ii) to the extent the defect in the Product is the direct result of improper installation, operation beyond the capability or not in accordance with Tecnorampa's instructions, careless or negligent use, or failure to maintain the Product as recommended by Tecnorampa or (iii) if the original purchaser fails to notify Tecnorampa of the defect within sixty (60) days after the defect is discovered.

In no event shall Tecnorampa be liable to anyone, including third parties, for special, indirect, collateral, punitive, incidental or consequential damages, even if Tecnorampa has been advised of the possibility of such damages. Such excluded damages include, but are not limited to, loss of goodwill, loss of profits, loss of use, business interruption or other similar indirect financial loss.

## ▶ 3.3 OWNER'S RESPONSIBILITY

The owner must recognize the inherent danger of the interface between the transport vehicle and the leveler.

The owner must train and instruct operators in the safe use of the platform dock leveler. Inspection procedures and periodic maintenance procedures recommended by the manufacturer must be followed.

The owner must ensure that all safety labels and instructions are posted on the leveler and are legible to the operator or maintenance personnel for whom these warnings are intended, as well as ensure that the appropriate operating and maintenance manuals are provided to the users. Levelers that are structurally damaged or have suffered a loss of support under load, which may occur when a transport vehicle is removed under the platform leveler, should be removed from service, inspected by an authorized representative of the manufacturer and repaired as necessary before being returned to service.

When a transport vehicle is positioned for loading and unloading, there must be a contact surface of at least 4" (100mm) between the leading edge of the lip of the leveler and the edge of the floor of the loading vehicle. When a vehicle is being driven on and off the transport vehicle during the loading and unloading operation through the platform leveler, the brakes of the transport vehicle must be applied and the wheels must be chocked with an appropriate wheel chock or using a vehicle restraint system.

The leveler must never be used outside of its vertical working range or vertical lift range or outside of the manufacturer's stated rated capacity.

## 4. Safety warnings

Improper operation can cause accidents. Do not take chances with incorrect or damaged equipment. Read and understand the procedures for safe operation and maintenance described in this manual. Do not hesitate to ask for help.

Stay alert! Follow safety rules, regulations and procedures. Avoid accidents by recognizing dangerous procedures or situations before they occur.

Safety signs and messages are placed in this manual to provide instructions and identify specific areas where potential hazards exist and special precautions should be taken. Knowing and understanding the meaning of these instructions, signs and messages can prevent and avoid damage to equipment, death or serious injury to yourself or others.

### 4.1 COLOR IDENTIFICATION OF SAFETY SIGNS AND SAFETY MESSAGES

This manual includes color-coded safety messages to identify instructions and specify areas where potential hazards exist.



This is the safety alert symbol. It is used to alert you to potential personal injury hazards. Obey all safety messages containing this symbol to avoid possible serious or fatal injury. The following is the color code established in this manual for safety messages.



#### DANGER

THIS MESSAGE INDICATES AN IMMINENT DANGER SITUATION WHICH, IF NOT AVOIDED, WILL RESULT IN DEATH OR SERIOUS HARM.



#### WARNING

THIS MESSAGE INDICATES A POTENTIALLY HAZARDOUS SITUATION WHICH, IF NOT AVOIDED, COULD RESULT IN DEATH OR SERIOUS INJURY.



#### CAUTION

THIS MESSAGE INDICATES A POTENTIALLY HAZARDOUS SITUATION WHICH, IF NOT AVOIDED, MAY RESULT IN MINOR OR MODERATE INJURY.



#### IMPORTANT

THIS MESSAGE IS USED WHEN SPECIAL PRECAUTIONS ARE IN PLACE AND MUST BE TAKEN TO ENSURE CORRECT ACTION OR TO PREVENT DAMAGE OR MALFUNCTION OF THE EQUIPMENT AND/OR A COMPONENT.

# ▣ 5. Safe practices

The following is intended to be a quick reference to some of the important procedures that should be followed when using the platform dock leveler. It is not intended to cover, nor does it suggest that it does, all procedures that must be followed to ensure safe operation. Operators should be aware of and comply with all workplace safety regulations that may apply to the operation of the platform dock leveler.



## WARNING

1. Do not install, operate and/or service this leveler unless you have been trained and authorized to do so.
2. Do not install, operate and/or service this leveler until you have read and understand all safety information and instructions contained in this manual.
3. Do not operate this leveler until you have verified its condition. Report the need for repairs to your supervisor immediately and do not operate the leveler until repairs are made. Negligence can turn a minor repair into a major service problem and make the leveler unsafe.
4. Do not work under or around the leveler being installed without first placing adequate barriers to prevent vehicle traffic from entering the work area.
5. All electrical wiring, connections, repairs and troubleshooting must be performed by qualified service personnel.
6. All wiring connections and repairs must be made to comply with all applicable codes. Before performing any electrical work, make sure the power is disconnected and properly tagged and/or locked out.
7. Before performing any maintenance, secure the platform leveler properly.
8. Do not load the leveler beyond the capacity shown on the leveler serial nameplate.
9. Stand clear of the platform leveler and the vehicle when the vehicle is backing up or leaving the platform area.
10. Secure the vehicle by chocking the vehicle wheels or using a vehicle restraint system before operating the platform leveler.
11. Do not use or move the platform leveler if someone is under, in front of, and/or on the platform leveler.
12. Keep hands and feet away from the platform leveler attachment points at all times. Never use your hands to lift the platform ramp and/or the edge of the vehicle or to put the platform leveler away.
13. Do not drive over the leveler unless the edge is firmly in contact on the vehicle platform and has a minimum projection of 4 "(100 mm) onto the vehicle platform.
14. Do not exceed the stated weight of the leveler when in use.
15. Do not drive over the edges of the leveler and/or the platform bumpers (bumpers are not structural).
16. Do not leave equipment or materials unattended on the leveler.
17. Do not leave the leveler unattended in the deployed position.
18. Do not use a forklift or other material handling equipment to lower the platform leveler.
19. Never attempt to make repairs. Refer to a qualified repair technician.
20. Use safety equipment as required.
21. Practical workplace guidance for the safe use of this product may restrict the use of any substance that may compromise or impair safe operational use.

---

This manual is intended to be readily available. Keep it near the leveler as a reference for anyone who may operate or repair it. If the leveler you are operating is not equipped with a manual, ask to obtain one and locate it near the leveler.

# 6. Pit installation requirements



## IMPORTANT

READ THE ENTIRE INSTALLATION AND OPERATION MANUAL BEFORE INSTALLING OR OPERATING THE RAMP.

DO NOT INSTALL THE RAMP ON ANY SURFACE OTHER THAN CONCRETE, CONFIRMING THAT IT MEETS THE MINIMUM SPECIFICATIONS.

### TECHNICAL DETAILS OF THE PIT

**NOMINAL DIMENSIONS:**

PIT WIDTH (W):  
74" (1880MM)

PIT LENGTH (L):  
85-1/4" (2165MM)

PIT HEIGHT (H1 AND H2): H1(REAR HEIGHT):  
19-1/2" (495MM) H2(FRONT HEIGHT): 20" (508MM)

PIT MATERIAL:  
CONCRETE WITH A STRENGTH OF 250KG/CM2 WITH AT  
LEAST 15CM (6") THICK

ANGLE OF PIT EDGES: 3" X 3" X 1/4" ANGLE

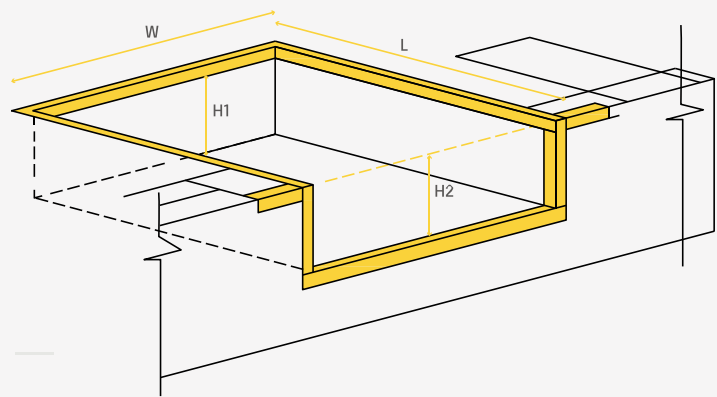

### TECHNICAL DETAILS OF LEVELER

	MODEL OF LEVELER	
	RNM306X716	RNM406X716
RATED CAPACITY	30000 LBS	40000 LBS
RATED DIMENSIONS	6'X7' (1829MM X 2134MM)	6'X7' (1829MM X 2134MM)
PLATFORM DIMENSIONS	72" X 83-3/8" (1829MM X 2118MM)	72" X 83-3/8" (1829MM X 2118MM)
LEVELING	+/- 12" WITH RESPECT TO PLATFORM LEVEL	+/- 12" WITH RESPECT TO PLATFORM LEVEL
STANDARD LIP	16"	16"
OPERATION SYSTEM	MECHANIC	MECHANIC
FINISH	LEAD GREY/YELLOW	LEAD GREY/YELLOW

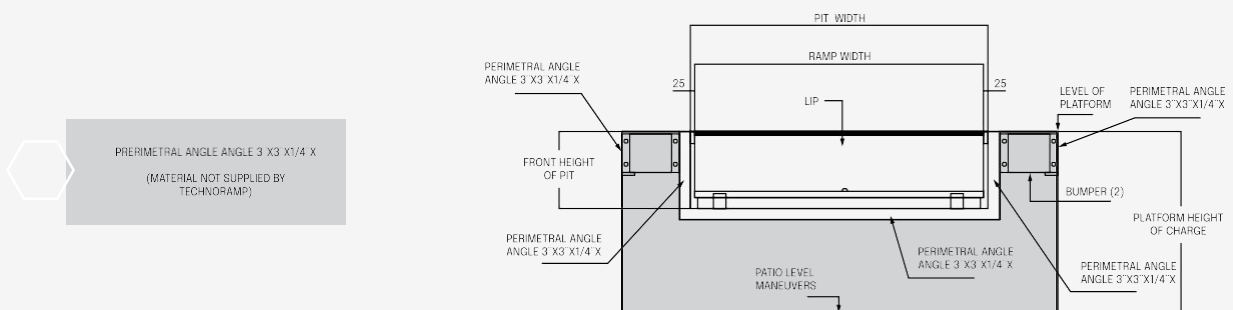

# 7. Installation

## 7.1 POINTS TO REVIEW BEFORE UNLOADING AND INSTALLING

### □ Pit dimensions

Always use architectural plans when they are available. Check the dimensions of the pit area, to make sure that such a space is suitable and the required space is available.

### □ Type of concrete

The ramps must be installed in concrete with a resistance of 250 kg/cm<sup>2</sup> with a minimum of 15cm (6") thick. If the concrete installed does not comply with at least this specification inform the personnel in charge and do not proceed with the installation of the leveler.

### □ Defective concrete

Visually inspect the area where the ramp will be installed and check for cracks or defects in the Concrete. In case of detecting any defect on the concrete, inform the supervisor or personnel in charge of the finding and do not proceed with the installation until the necessary repairs have been made.

## 7.2 INSTALLATION PROCESS

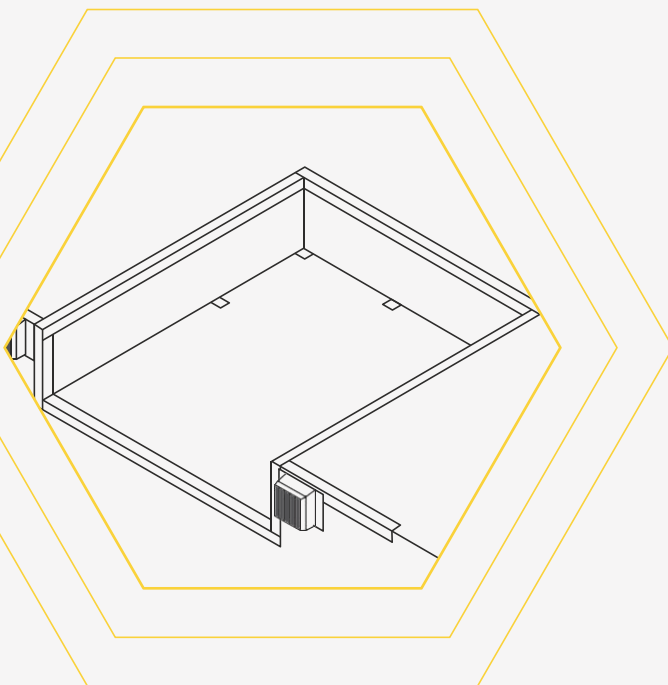

- 1 Unload the ramp and place it near the area where you will try to install it.
- 2 Remove the shipping bands and packing material from the unit.
- 3 Remove the packaging supports.
- 4 Check the quantity of all components with the parts list. If there are missing parts, please contact your ramp supplier.
- 5 Next, measure the depth of the rear corners of the platform pit and do the same with the front corners of the pit.
- 6 Place plate and sheet metal shims to match the height of the rear frame of the grader with the rear edge of the pit as shown.

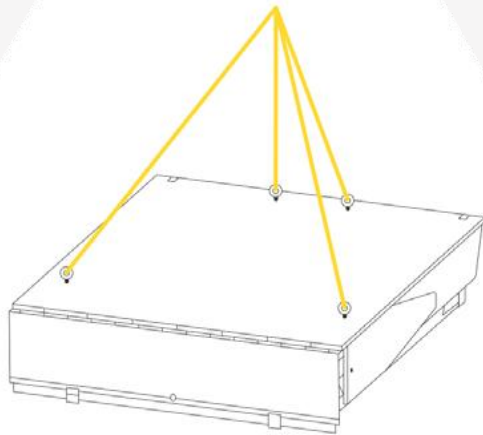

7 Using slings or chains for a minimum capacity of 1000 Kg, lift the ramp from the appropriate attachment points as shown below and carefully position it inside the pit. Make sure that the gap between the sides of the grader and the sides of the pit is equal. Also, check that the positioned shims are suitable for leveling the rear edges of the pit and leveler. Add or remove shims as needed.

8 Next, release the front lip clamping screw and pull the drive chain slightly to allow the platform to be raised slightly without actuating the lip mechanism.

9 Walk on the platform to return the leveler to its stored position making sure that the lip rests correctly on the front supports.

10 Check the front height of the platform and adjust the height with shims if required.  
Note: It is recommended that the front of the leveler is always below the platform level.

11 Carefully inspect that the rear frame is perfectly aligned with the perimeter angle from the pit. Add or remove shims as needed.

12 Also inspect the height and front alignment of the ramp. Add or remove shims as needed.

13 Proceed to welding the rear and front frames to secure the leveler in position.  
Use 1/8" 7018 weld to apply evenly spaced weld beads on the contact surface between the rear frame of the leveler and the perimeter angle of the pit. Do the same with the contact surface between the face plate of the leveler base and the front angle of the pit.

14 Once the leveler has been secured in its position, proceed to perform functional tests of the unit to ensure its correct operation, follow the instructions described in Section 8 OPERATION METHOD. If necessary, make the necessary adjustments following the instructions in Section 10 MECHANICAL LEVELER ADJUSTMENT.

# 8. Form of operation



## WARNING

BEFORE OPERATING THE PLATFORM LEVELER, ALWAYS IMMOBILIZE THE TRUCK WITH A RETAINER OR WHEEL CHOCKS.  
DO NOT OPERATE THE PLATFORM LEVELER IF THERE IS SOMEONE STANDING ON IT OR IN FRONT OF IT.  
DO NOT MANUALLY RAISE THE LEVELER LIP.  
ALWAYS KEEP YOUR HANDS AND FEET AWAY FROM MOVING PARTS.  
AFTER SERVICING THE TRUCK, ALWAYS RETURN THE LEVELER TO THE SAFE POSITION AT THE PLATFORM LEVEL, WITH THE LIP HELD IN THE CORRESPONDING LOCKS.  
DO NOT DRIVE ON THE LEVELER UNLESS THE EDGE IS FIRMLY IN CONTACT ON THE VEHICLE PLATFORM AND HAVE A MINIMUM PROJECTION OF 4" (100 MM) ON THE VEHICLE PLATFORM.  
DO NOT OPERATE THE LEVELER ABOVE ITS SET CAPACITY. DO NOT EXCEED 6.5 KM/H WHEN DRIVING ON THE LEVELER.  
DO NOT DRIVE OVER THE EDGES OF THE LEVELER AND/OR THE PLATFORM STOPS (THE STOPS ARE NOT STRUCTURAL)

### 8.1 LEVELER LIFTING

1.

Before operating the platform leveler, immobilize the truck with a retainer or wedges on the wheels

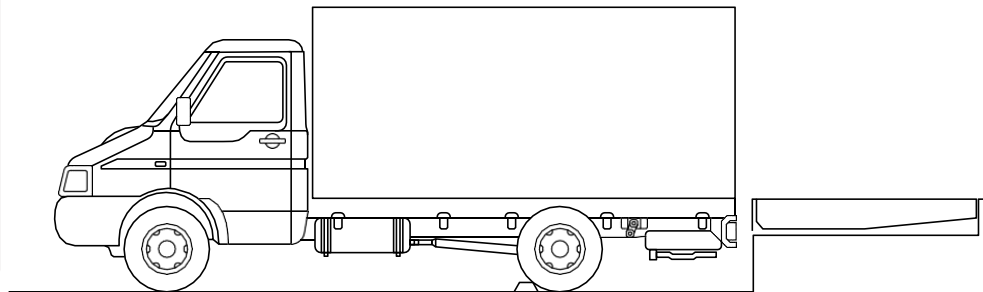

2.

To raise the leveler, pull and hold the locking release chain located on the back. When the leveler is fully raised, the lip will be extended automatically.

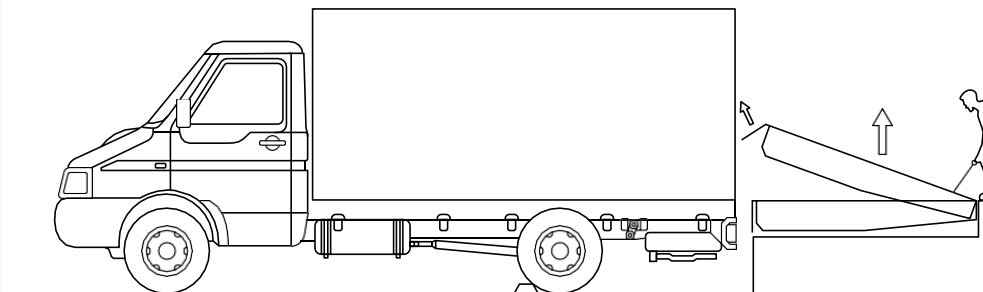

## WARNING

NOTE: IF THE LIP IS NOT FULLY EXTENDED, DO NOT LIFT IT MANUALLY. BRING THE LEVELER BACK TO THE PLATFORM LEVEL AND TRY AGAIN. IF THE LIP IS NOT FULLY EXTENDED, THE PLATFORM LEVELER NEEDS MAINTENANCE OR ADJUSTMENT. NOTIFY YOUR SUPERVISOR. DO NOT USE THE LEVELER UNTIL IT IS REPAIRED. FAILURE TO DO SO COULD RESULT IN SERIOUS OR FATAL INJURY.



3.

Release the chain when the lip is fully extended. Walk to the front of the ramp. The platform leveler will descend until the lip rests in the truck.

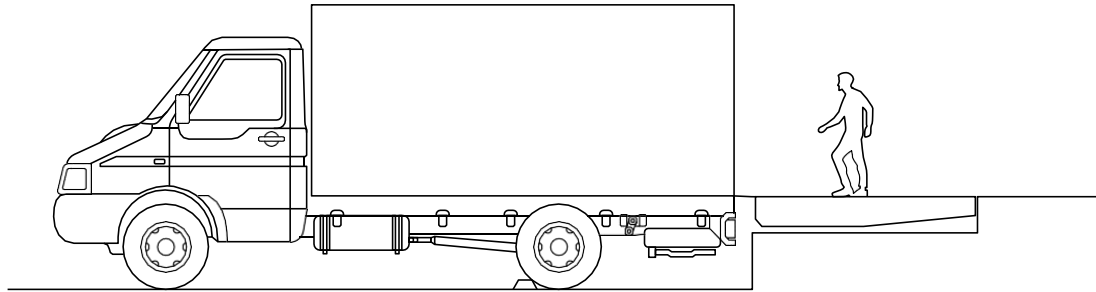

4.

To bring the ramp below the platform level pull the release chain of the anti-fall mechanism on the middle front of the ramp and continue walking to the front of the ramp to lower it to the desired level.

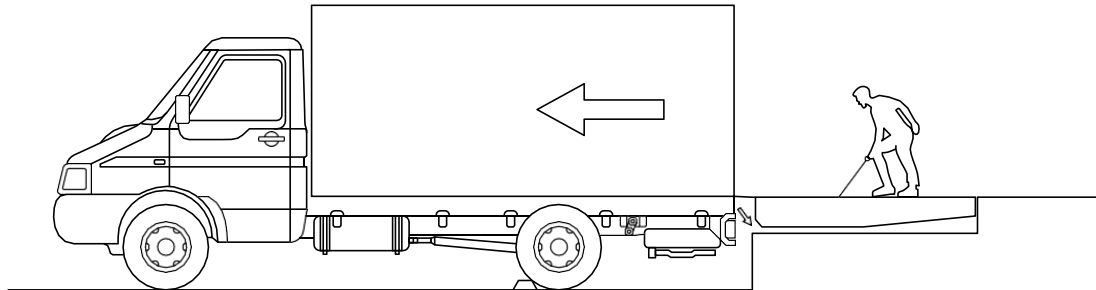

## WARNING

NEVER WALK ON THE LIP OF THE LEVELER TO LOWER THE PLATFORM LEVELER.

### ► 8.2 PLACE LEVELER IN THE REST POSITION

1.

To bring the leveler back to the rest position after use on a platform transport, detach the unit from the platform and the lip will drop to the rest position automatically.

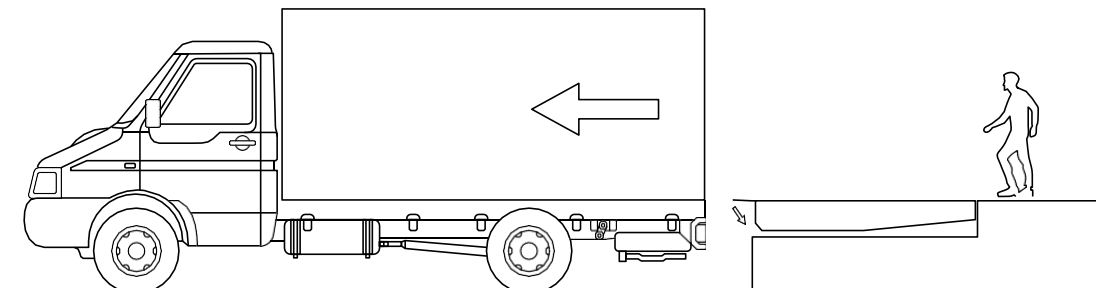

2.

Once the lip is fully retracted and detached from the truck, pull the release chain gently to raise the leveler partially and walk to the front of the ramp. The platform leveler will descend until the lip rests on the corresponding locks.

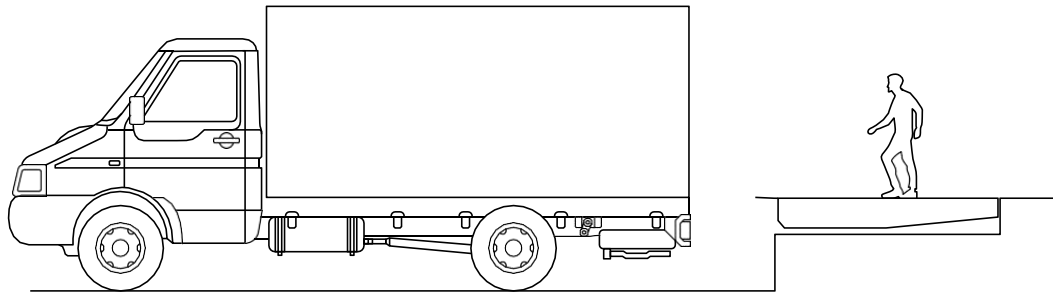

### ▶ 8.3 PLACE LEVELER IN THE REST POSITION (MANUAL LIP LOWERING)

1.

To bring the leveler back to the rest position, pull the release chain gently to raise the leveler to a height of no more than 12', or in case it is completely raised the leveler walk to the front of the ramp to reach the mentioned height.

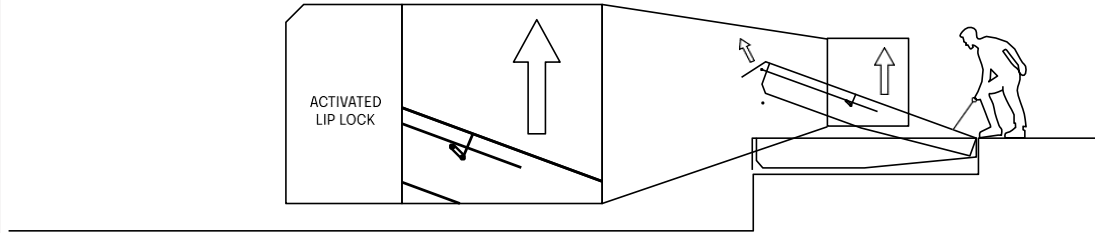

2.

Once the leveler meets the height (12'), release the lip by lifting it manually, this will release the lip lock and then let it fall gently.

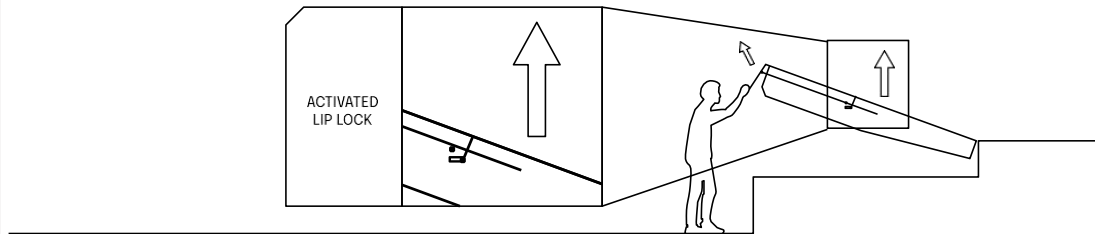

3.

Once the lip is completely retracted, walk to the front of the ramp. The platform leveler will descend until the lip rests on the corresponding locks.

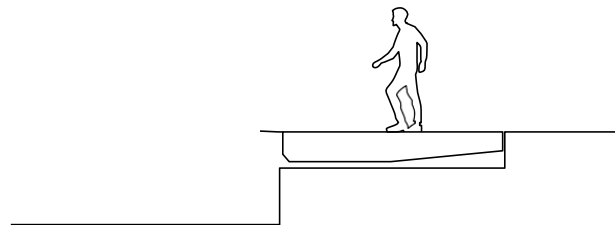

# ft. Maintenance of the equipment



**DANGER**

Before installation/maintenance/adjustment, place suitable barriers to prevent unauthorized personnel and vehicle traffic from entering the work area.



**DANGER**

Before carrying out any adjustment work, place the maintenance baton in position



**WARNING**

All repairs and maintenance work must be performed only by trained and authorized personnel.

## 9.1 PREVENTIVE MAINTENANCE

Every 10 days of operation check the following points:

- ▶ Check for traces of materials on the lip hinge. Clean it as needed.
- ▶ Check for material debris in the area of the leveler's rear hinge and between the sides and edge angles, to ensure proper operation. Clean them as needed.
- ▶ Check the safety baton system to make sure it is working properly and has no structural defects, pull the chain and check the operation of the recoil spring.
- ▶ Check the operation of the foot guards to make sure that they are not deformed or jammed when the leveler is used.
- ▶ Check that the bolts have their cotter pin in place. Do not operate the ramp if any of the bolts do not have their insurance. Replace them if necessary.
- ▶ Check that the platform stops are present.

Every three months or every 250 hours of operation:

- ▶ Clean the inside of the pit area.
- ▶ Clean the frame and brake gears. Apply a thin layer of oil on the gears and on all sides of the frame.
- ▶ Check if the wear of the main springs and the lip lock is excessive.
- ▶ Check if the pusher Trolley assemblies and its roller are damaged.
- ▶ Check all welds under the leveler for fatigue or failure, especially the lip plate hinge, the upper plate beams, and the front hinge bar.
- ▶ Check the entire operation of the leveler. Make the required settings.
- ▶ Lubricate the lip and platform hinges with grease. Do not over-grease. Stop greasing when the grease begins to flow down the ends of the hinge tube. Remove excess grease with a cloth.
- ▶ Check all labels and warning signs. Replace them as needed.
- ▶ Check the platform stops. If they are worn out or not present replace them.

9.2 CHECKLIST OF INSPECTION PROCEDURES BEFORE OPERATING THE RAMP



## WARNING

All repairs and maintenance work must be performed ONLY by trained and authorized personnel.



## DANGER

Prior to installation/maintenance/adjustment, place adequate barriers to prevent unauthorized personnel and vehicular traffic from entering the work area. Before performing any adjustment work place the maintenance rod in position.

### MECHANICAL DOCK LEVELER

Serial number \_\_\_\_\_

Platform # \_\_\_\_\_

Date \_\_\_\_\_

**Instructions:**

Use the [✓] mark in the appropriate box of each inspection point to indicate that it is in optimal condition for use.

Use the [x] mark in the appropriate box of each inspection point to indicate that it is not in optimal condition.

Every day (Can be performed by owner or assistant):

- Check for material debris in the rear hinge area of the leveler and between the sides and edge angles to ensure smooth operation.
- Verify that the platform dock leveler operates smoothly.
- Check that the platform stops are present.
- Check the platform for irregularities such as cracks in the concrete.
- Verify that the work area around the platform is clear. Eliminate any potential tripping hazards.
- Verify the interior and exterior lighting system and external signage is present and legible (if equipped).
- Check that wheel chocks or vehicle restraint system are in good working condition.

Explain the failures briefly in the space provided below:

---

---

---

---

---

9.3 TROUBLESHOOTING GUIDE



# DANGER

Do not attempt to perform installation, repair, maintenance or adjustment work. Such work should be performed ONLY by trained and authorized personnel. Contact your local distributor for assistance.

PROBLEM	POSSIBLE CAUSE	PROBLEM SOLUTION
The platform does not rise	<ol style="list-style-type: none"> <li>1. The brake mechanism is not releasing. The release chain, lever or sprocket block may be broken.</li> <li>2. Foreign material may be jammed between the side of the platform and the pit wall.</li> <li>3. Platform bumpers may be damaged or missing, allowing the truck to contact and stop the lip.</li> <li>4. Main springs may require adjustment.</li> </ol>	<ol style="list-style-type: none"> <li>1. Inspect the brake mechanism and repair or replace as necessary.</li> <li>2. Inspect pit sides and remove material that could affect operation.</li> <li>3. Replace any damaged or missing walk stops.</li> <li>4. Adjust spring tension as shown in section 10.2 (take into consideration the version of ramp you wish to adjust - 30000 or 40000 lbs).</li> </ol>
Platform does not rise fast enough to drive the lip to the fully extended position	<ol style="list-style-type: none"> <li>1. Foreign material jammed in the lip hinge, preventing full rotation.</li> <li>2. Platform may be rubbing on the side of the pit, stopping it from moving.</li> <li>3. Foreign material jammed between platform side and pit.</li> <li>4. Lack of lubrication on the lip hinges.</li> <li>5. Main tension springs may require adjustment (check other causes first).</li> </ol>	<ol style="list-style-type: none"> <li>1. Inspect lip hinges and remove any foreign material.</li> <li>2. Verify that the clearances between the platform side and the pit are correct. (See section 6 INSTALLATION REQUIREMENTS IN PIT).</li> <li>3. Inspect the sides of the pit and remove material that could affect performance.</li> <li>4. Apply multi-purpose grease through the 1/8" NPT grease fittings installed in the hinges.</li> <li>5. Adjust spring tension as shown in section 10.2 (take into consideration the version of ramp you wish to adjust - 30,000 or 40,000 lbs).</li> </ol>
The lip does not hold after full extension.	<ol style="list-style-type: none"> <li>1. Lip rod is bent or broken.</li> <li>2. Foreign material is jammed in the lip lock mechanism.</li> <li>3. The lip lock mechanism is not engaging. Spring may be broken or compressed.</li> <li>4. Lip spring needs more compression.</li> <li>5. Lip stick clevis may require adjustment. (Discard the above option first).</li> </ol>	<ol style="list-style-type: none"> <li>1. Visually inspect the lip stick. Replace if necessary.</li> <li>2. Inspect the lip lock mechanism and remove any foreign material.</li> <li>3. Inspect the lip lock spring. Replace as necessary.</li> <li>4. Adjust the lip spring compression as shown in section 10.4.2.</li> <li>5. Adjust the lip stick clevis as shown in section 10.4.1.</li> </ol>

# 10. Adjustment of mechanical leveler

## 10.1 MAINTENANCE BAR

1. To raise the maintenance bar :
  - a. Pull the brake release chain to raise the platform leveler to the maximum position above the platform.
  - b. Pull the maintenance bar up and forward.
  - c. Position the bar safety pin and drop it to the immobilized position.
2. To bring the maintenance bar downward:
  - a. Remove the safety pin from the bar.
  - b. Pull the maintenance bar down and back. It will then lower to the rest position.

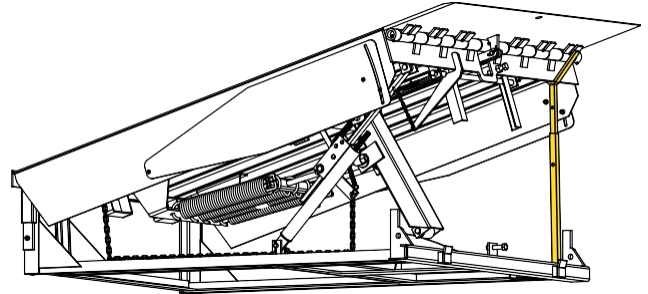

## 10.2 ADJUSTMENT OF MAIN SPRING CLIPS

The main spring should be adjusted so that the leveler rises high enough for the lip to extend and jam the latch.

Before servicing the platform leveler, always place traffic cones or a barricade behind the leveler to warn forklift operators and pedestrians away from the leveler.

Always place traffic cones in front of the leveler to prevent vehicular traffic.

Always notify a foreman or supervisor that you are working under equipment.

Always make sure the maintenance bar is in the raised position before working under the platform leveler.

### 10.2.1 LEVELER ADJUSTMENT 30,000 LBS

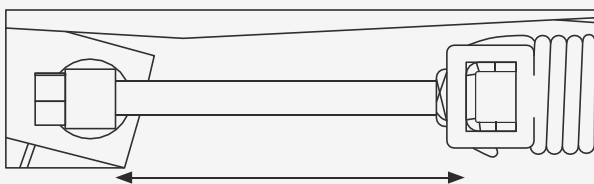

VOLTAGE RANGE FOR CORRECT OPERATION  
13.5 CM - 14.5 CM

### 10.2.2 LEVELER ADJUSTMENT 40,000 LBS

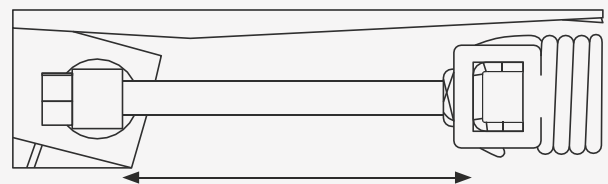

VOLTAGE RANGE FOR CORRECT OPERATION  
18 CM - 19 CM



## WARNING

EXTENDED SPRINGS HAVE STORED ENERGY. NEVER ATTEMPT TO REMOVE THE MAIN SPRINGS BEFORE THE LOAD HAS BEEN COMPLETELY REMOVED. DO NOT REMOVE MAIN SPRINGS UNTIL THE LEVELER AND LIP ARE SECURELY SUPPORTED BY A SUITABLE LIFTING DEVICE.

## ▶ 10.2.3 MAIN SPRING ADJUSTMENT PROCEDURE

USE 1-1/2" SOCKET TO ADJUST  
4 SPRINGS OF  $\varnothing 1/2"$

NO. SPIRALS: 40

ROLLED: STRAIGHT

ENDS: RAISED SPECIAL SIZE

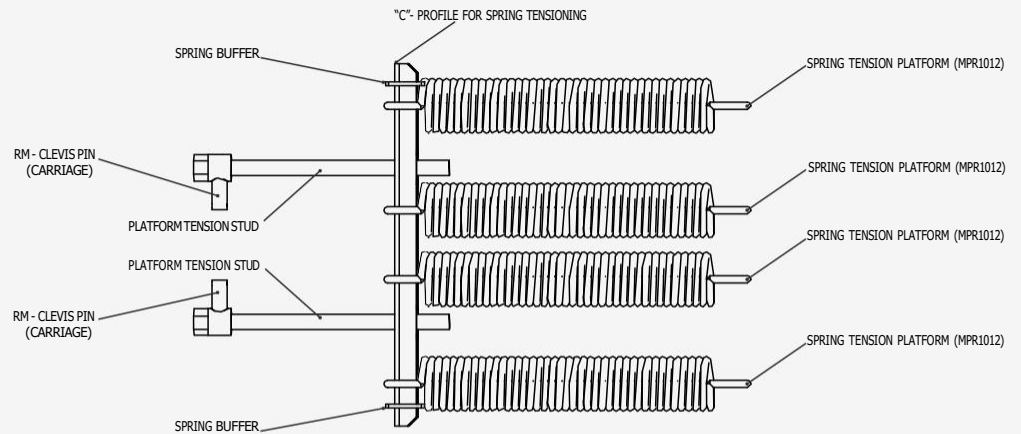

1. If the lip does not extend fully, turn the two platform tensioning studs clockwise one-half turn to increase the main spring tension. Check the operation of the ramp with this adjustment.

If necessary continue to make half turn adjustments on each adjusting nut and check operation each time until the ramp operates properly.

Once the ramp is functioning properly, turn both nuts a final half turn.

2. If the leveler exerts too much resistance when walking on it, turn the platform tensioning studs counterclockwise one-half turn to reduce the main spring tension. Check to see if the downward resistance has decreased and verify that the lip extension mechanism has not been affected.

If necessary continue to make half turn adjustments on each stud and check operation each time.



## IMPORTANT

MAINTAIN THE ADJUSTMENT DISTANCES OF THE MAIN SPRINGS WITHIN THE RANGES ESTABLISHED IN SECTION ACCORDING TO THE CORRESPONDING RAMP MODEL.

## ▶ 10.3 TENSION SPRING WITH LIP LATCH HOOK

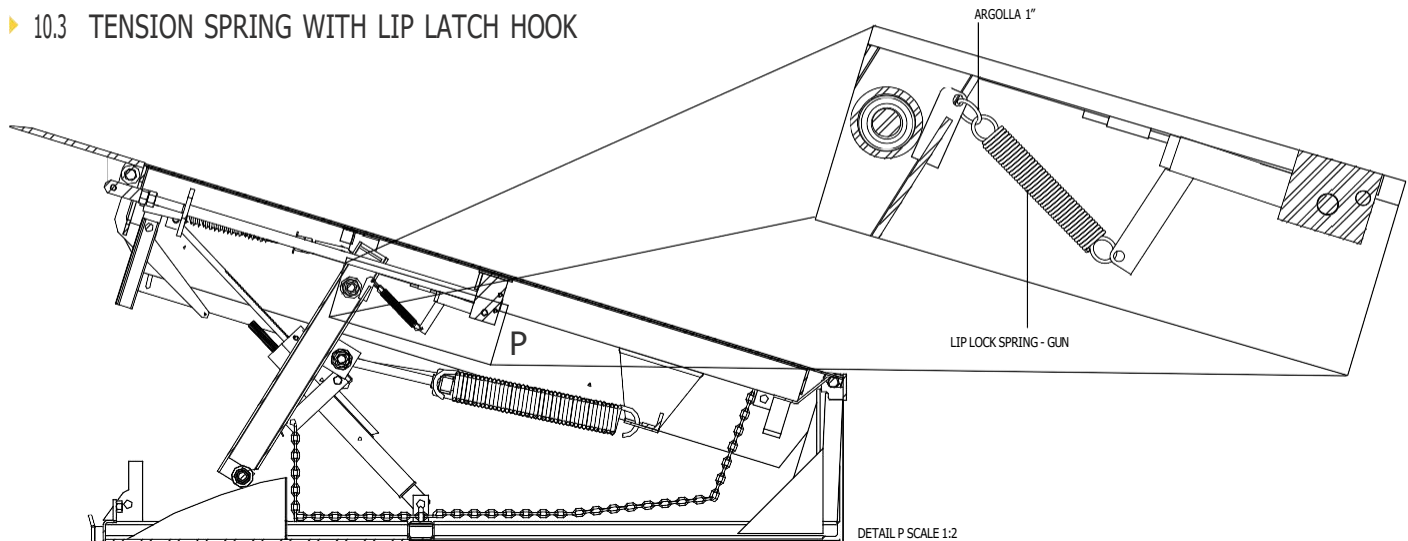

**NOTE:** The lip lock is already set at manufacture.

## 10.4 LIP PUSH STICKS

The lip push stick system must be adjusted so that the lip is fully extended, reaches the desired working height and engages properly in the locking system.

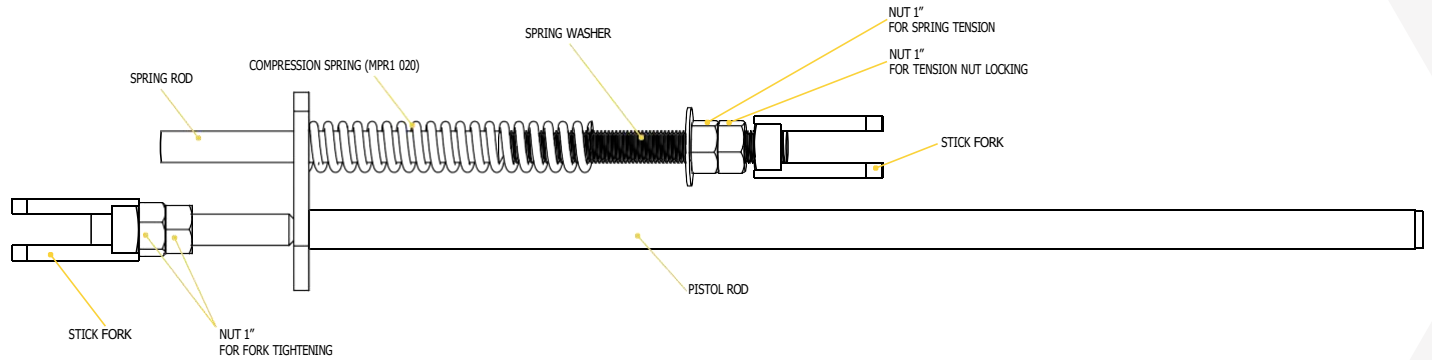

### 10.4.1 STICK CLEVIS ADJUSTMENT

The adjustment distance set on the pole fork for a correct working of the lip and lip attachment system is 14.5 cm.

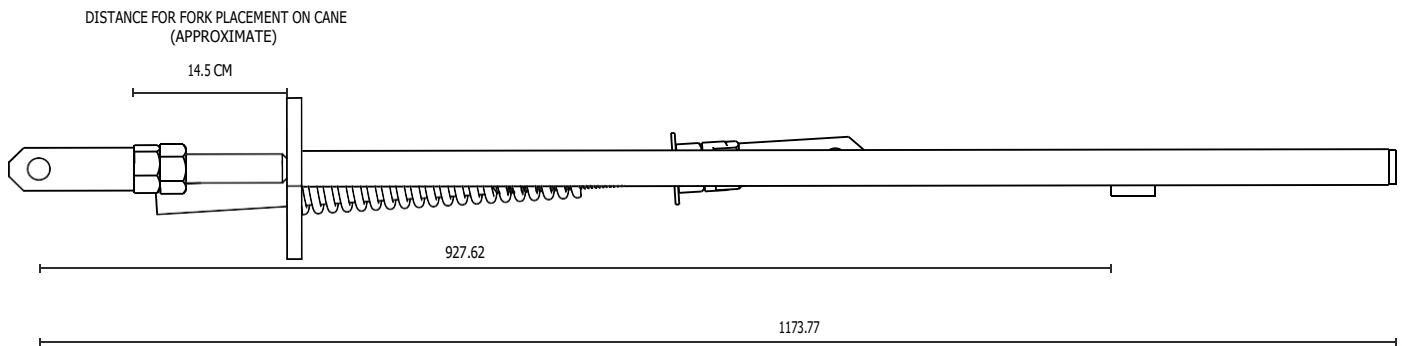

1.- If the lip does not reach the working height stated in section 11.7 of this document, loosen the gun stick clevis tightening nuts and remove the lip clevis bolt - stick clevis. Rotate the clevis one turn clockwise and check the lip working height clearance. Put the bolt back in position and retighten the clevis tightening nuts.

2.- If the lip is above the working height stated in section 11.7 of this document, it is likely that the lip locking system is not working properly, to adjust to the correct size loosen the gun stick clevis tightening nuts and remove the bolt from the lip clevis - stick clevis. Turn the clevis counterclockwise one turn and check the working height distance of the lip. Put the bolt back in position and retighten the clevis tightening nuts.



## IMPORTANT

DO NOT PERFORM LIP CLEVIS ADJUSTMENT UNLESS YOU HAVE READ AND UNDERSTOOD THIS DOCUMENT AND FULLY UNDERSTAND HOW THE MECHANICAL RAMP WORKS. ADJUSTMENTS OF MORE THAN 2 TURNS ON THE STICK CLEVIS ARE NOT RECOMMENDED. DOING SO COULD CAUSE THE LIP LOCK SYSTEM TO MALFUNCTION AND AFFECT ADJUSTMENTS ON OTHER COMPONENTS.

## 10.4.2 LIP STICK SPRING

The lip push stick system must be adjusted so that the lip is fully extended, reaches the desired working height and engages properly in the locking system.

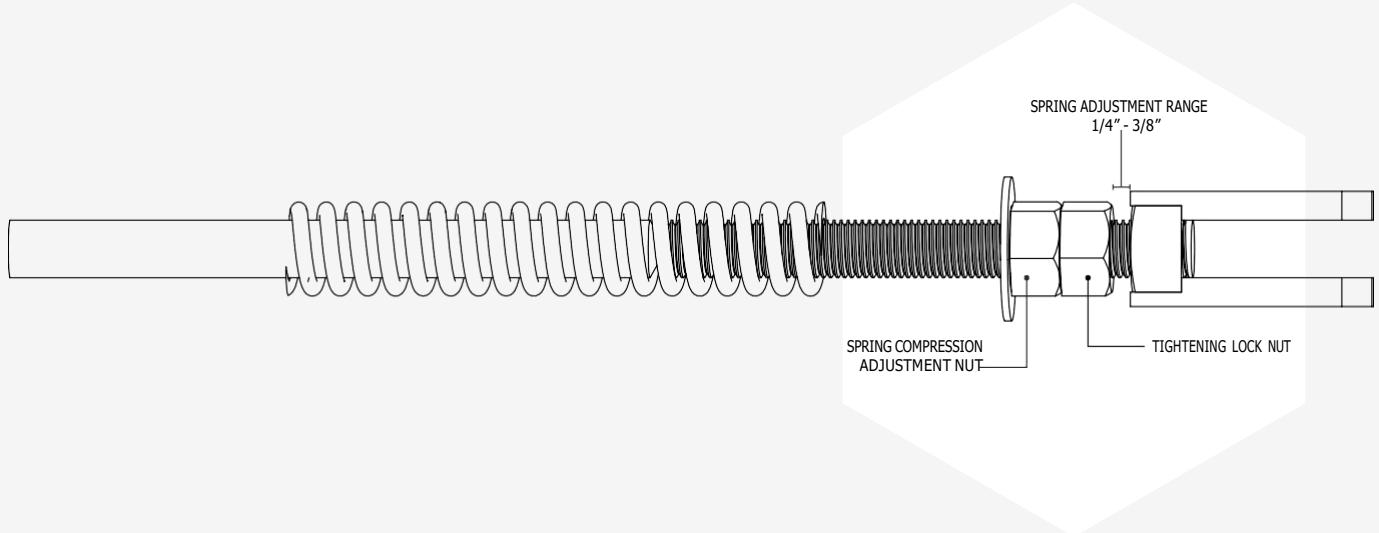

1.

If the lip does not fully extend and does not engage the locking mechanism, loosen the spring compression locknut and turn the spring compression adjustment nut clockwise one-half turn. Check the operation of the ramp with this adjustment. Verify that the lip returns to its stored position without any problems when the ramp is lowered.

If necessary continue to make half turn adjustments to the adjusting nut and check operation each time until the ramp operates correctly.

Once the ramp is working, retighten the spring lock nut to secure the adjustment position.

2.

If the lip does not return to its stored position when the ramp is lowered and the locking mechanism is releasing properly, loosen the spring tightening locknut and turn the spring compression adjustment nut counterclockwise one-half turn. Check the operation of the ramp with this adjustment. Verify that the lip lifts properly to its correct working position.

If necessary continue to make half turn adjustments to the adjusting nut and check the operation each time until the ramp operates correctly.

Once the ramp is working, retighten the spring lock nut to secure the adjustment position.



### IMPORTANT

KEEP THE LIP SPRING ADJUSTMENT DISTANCES WITHIN THE ESTABLISHED RANGE ( $1/4'' - 3/8''$ ) TO ALLOW FOR PROPER OPERATION OF THE MECHANICAL LEVELER.

## ▶ 10.5 LIP STICK SPRING

- The lip spring must be adjusted so that when the leveler is raised the lip lifts and the stick engages in the lip locking mechanism.

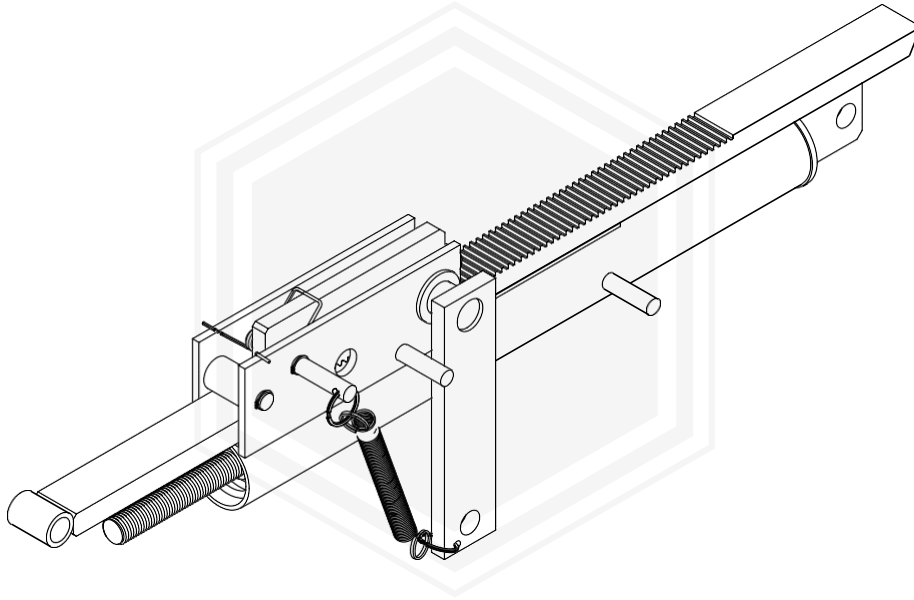

- The brake spring is set from manufacture at a distance of 2 inches as shown in the figure.

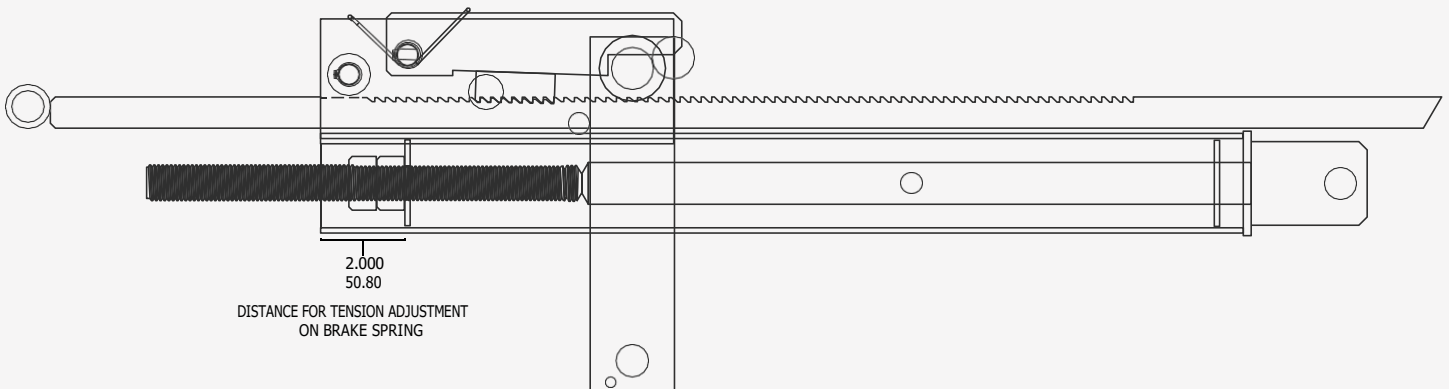

If the platform has too much movement when in any of the working positions or in the stowed position, the brake system may require adjustment. To make adjustments follow the process below. Using a 4" long die, for 1.125" nut

- 1 Place the maintenance rod in position before beginning to make adjustments to any system. Turn the adjusting nuts on the rod inside the cylinder clockwise if less platform movement is required. Make 1 turn adjustments and test until the desired setting is achieved.

## ▶ 10.6 LIP STOP SCREW ADJUSTMENT

The lip stop screw is used to limit the angle at which the lip is stored so that it can rest correctly on the corresponding brackets.

The factory set adjustment distance for this screw is 50mm and may require adjustment in the range of 45mm to 55mm.

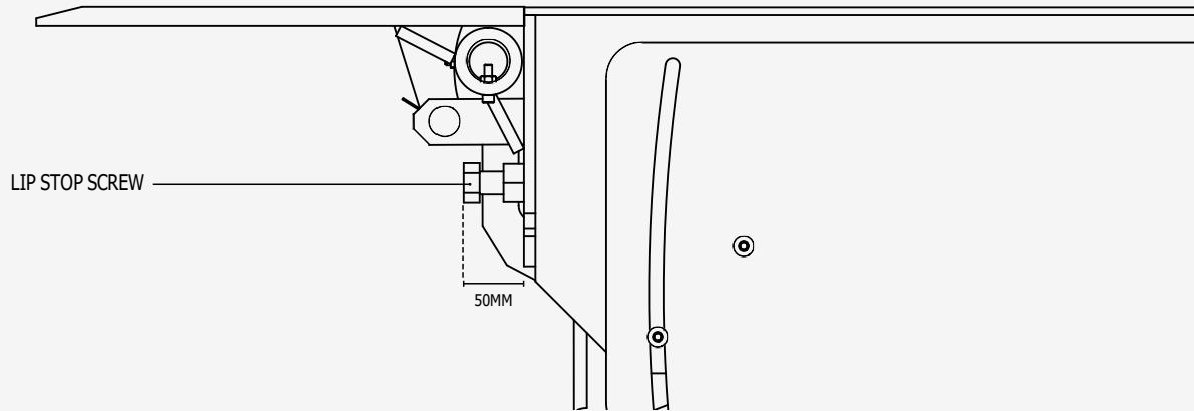

## ▶ 10.7 RAMP MEASUREMENTS FOR ADJUSTMENT REFERENCE

12" elevation clearance above platform level.

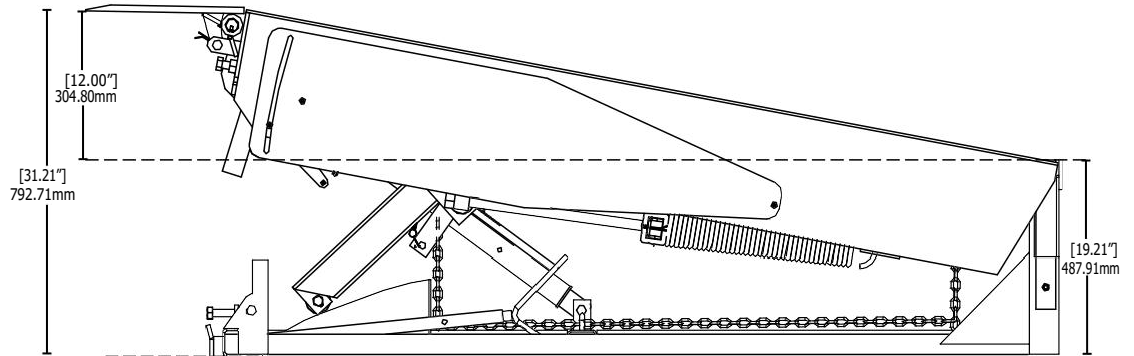

12" drop distance below platform level.

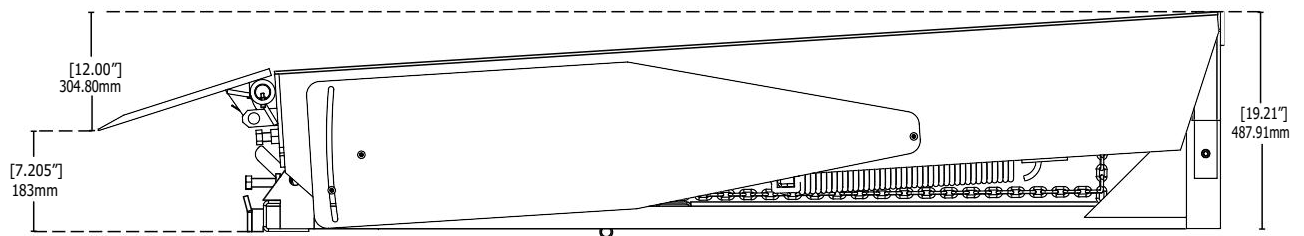

15.5" - 15.75" distance between lip end and bottom end of faceplate. Recommended distance for proper operation of the lip lock system and the tension settings established for the cane spring.

DISTANCE FOR LIP HEIGHT ADJUSTMENT

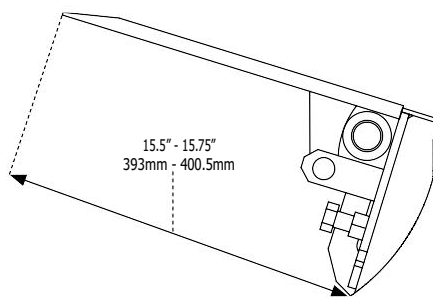

DETAIL R SCALE 1 : 4

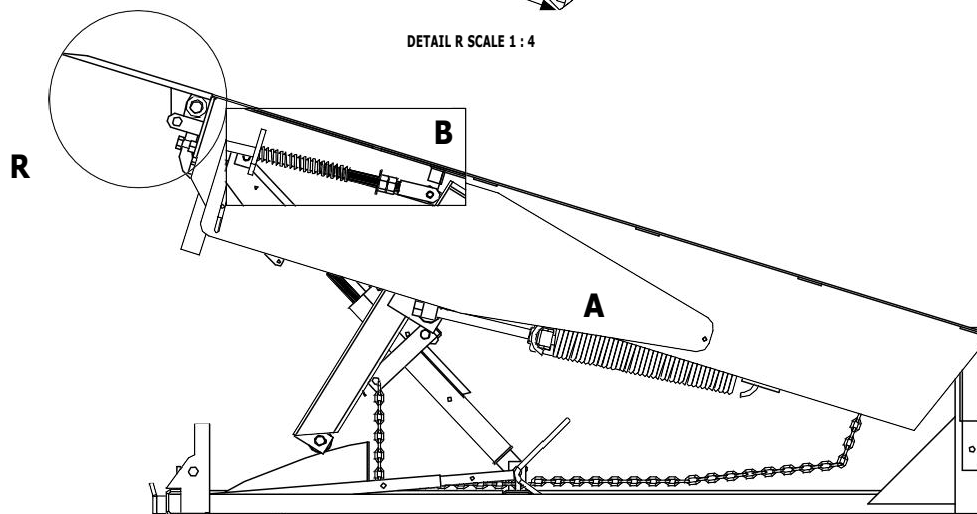

# 11. Inventory of parts

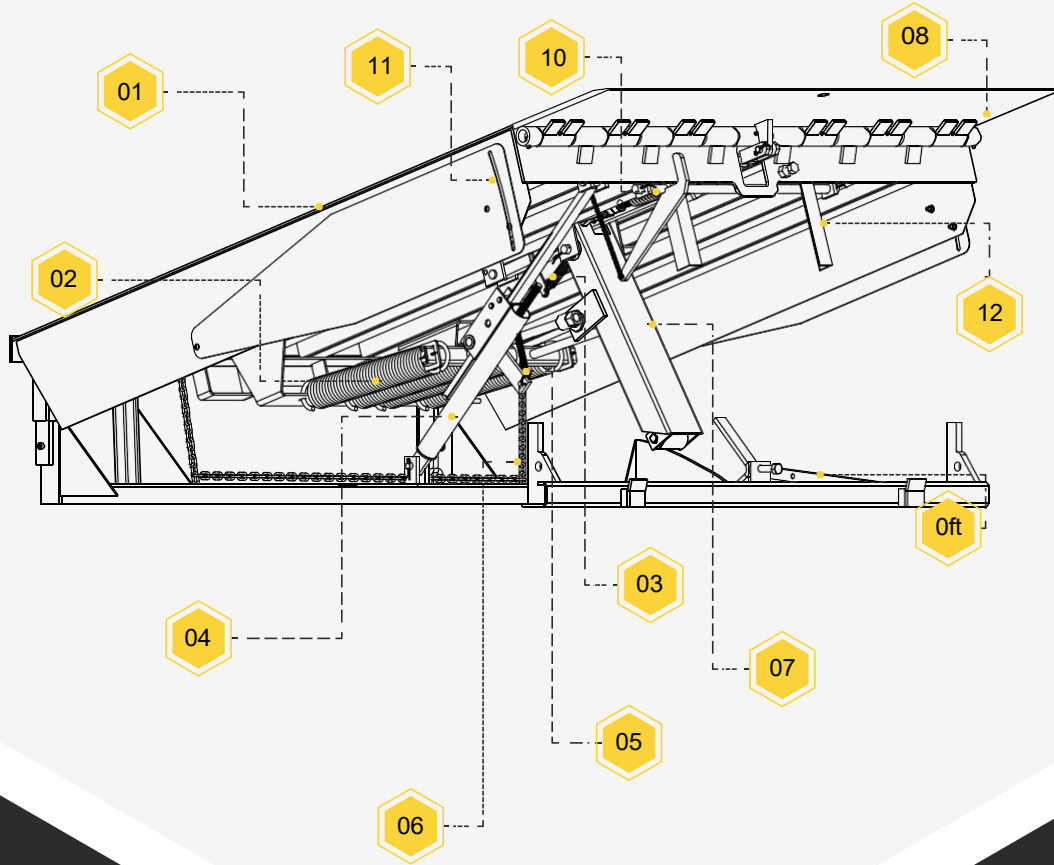

NO.	DESCRIPTION
01-	Mechanical ramp platform
02-	Tension spring for main ramp
03-	Tension spring with hook for lip lock
04-	Ramp brake
05-	Tension spring with hooks for brake lock
06-	Chain to operate the ramp
07-	Ramp trolley
08-	Lip
09-	Maintenance Bar
10-	Lip push spring
11-	Lateral protective Guard
12-	Anti-Fall System



▶ 11.1 EXPLOSION OF MECHANICAL LEVELER PARTS

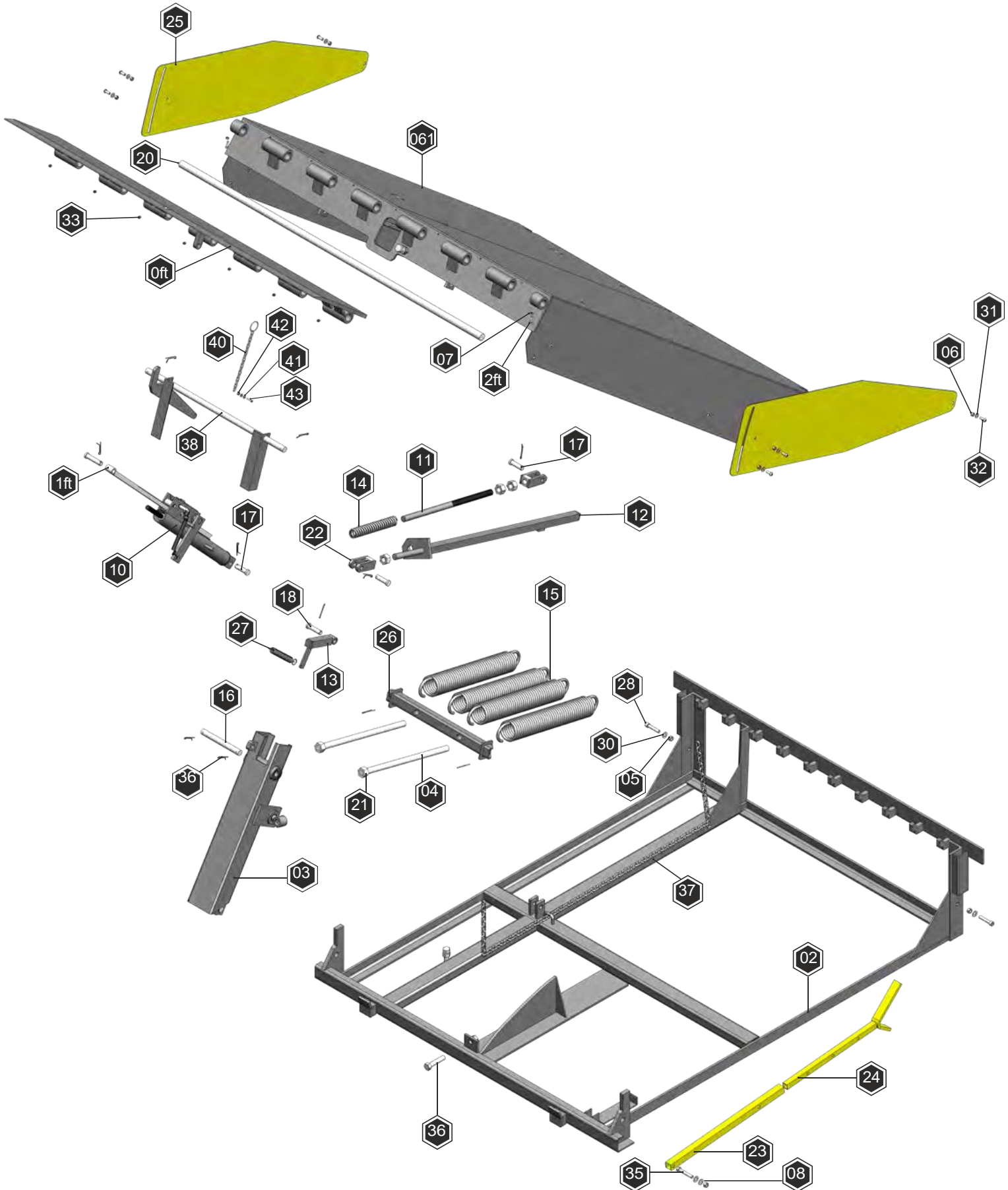

## ▶ 11.2 MECHANICAL LEVELER PARTS LIST

ITEM	PART NAME	QUANTITY		CODE	
				RNM306x816 (30000LBS)	RNM306x816 (40000LBS)
01	Platform	1	PART	RNM30-PTF	RNM40-PTF
02	Base Structure	1	PART		RNM-ESTB
03	Carriage Assembly	1	PART		RNM-ASSY-CR
04	Hex Blued Nut	1"-8	5	PART	MPTOR1398
05	Hex Nut Safety	1/2"-20	2	PART	MPTOR1013
06	Hex Nut Safety	3/8"-16	6	PART	MPTOR1105
07	Hex Blued Nut	1/4"-28	2	PART	PMPTOR1100
08	Hex Nut Safety	1/2"-13	1	PART	MPTOR1013
09	Lip Plate	1	PART	RNM30-PLLA	RNM30-PLLA
10	Ramp Brake	1	PART		RNM-ASSY-FR
11	Spring Rod Lip	1	PART		RNM-BAS01
12	Pistol Rod	1	PART		RNM-BAS02
13	Pistol Safety Lip	1	PART		RNM-PIS01
14	Lip Compression Spring	1	PART		MPR1020
15	Central Tension Spring	(MPR1012)	1	PART	MPR1012
16	Carriage Bolt	25mm	1	PART	MAQ1393
17	Bolt S	0.735"	3	PART	MAQ1380
18	Bolt L	0.700"	1	PART	MAQ1396
19	Bolt M	0.735"	1	PART	
20	Hinge Bolt	1-1/4"	1	PART	RNM-PERB-01
21	Stud Tension Platform	2	PART	RNM30-ETP-01	RNM40-ETP-01
22	Cane Fork	2	PART		RNM-HRQ-01
23	Shirt Cane Maintenance	1	PART		RNM-BASM01
24	Safe Cane Maintenance	1	PART		RNM-BASM02
25	Side guard	2	PART		RN-GRDL-01
26	Profile C Voltage	1	PART		RNM-PCT
27	Pistol Spring Lip Lock	1	PART		MPR1018
28	Black Allen Screw	1/2"-20x2-1/2"	2	PART	MPTOR1256
29	Black Allen Screw	1/4"-28x1"	2	PART	MPTOR1153
30	Flat Washer	1/2"	4	PART	MPTOR1003
31	Flat Washer	3/8"	6	PART	MPTOR1004
32	Drop Head Screw	3/8"-16x1"	6	PART	MPTOR1371
33	Grease fitting	1/8NPT	7	PART	MPTOR1493
34	Hex Screw	3/4"-10x3-1/2"	1	PART	MPTOR1277
35	Hex Screw	1/2"-13x3"	1	PART	MPTOR1369
36	Cotter Pin	1/4"x2	11	PART	MPTOR1464
37	Galvanized Chain	1/8"	2.2	METERS	MPTOR1425
38	Anti Fall System		1	PART	RNM-SAC
39	Bar Tensioner Spring	(MPR1025)	1	PART	MPR1025
40	Anti Fall System Chain	1/8"	18	LINKS	MPTOR1425
41	Flat Washer	3/16"	2	PART	MPTOR1005
42	Security Hex Nut	3/16"-24	1	PART	MPTOR1012
43	Black Allen Screw	3/16"-24x1"	1	PART	MPTOR1038

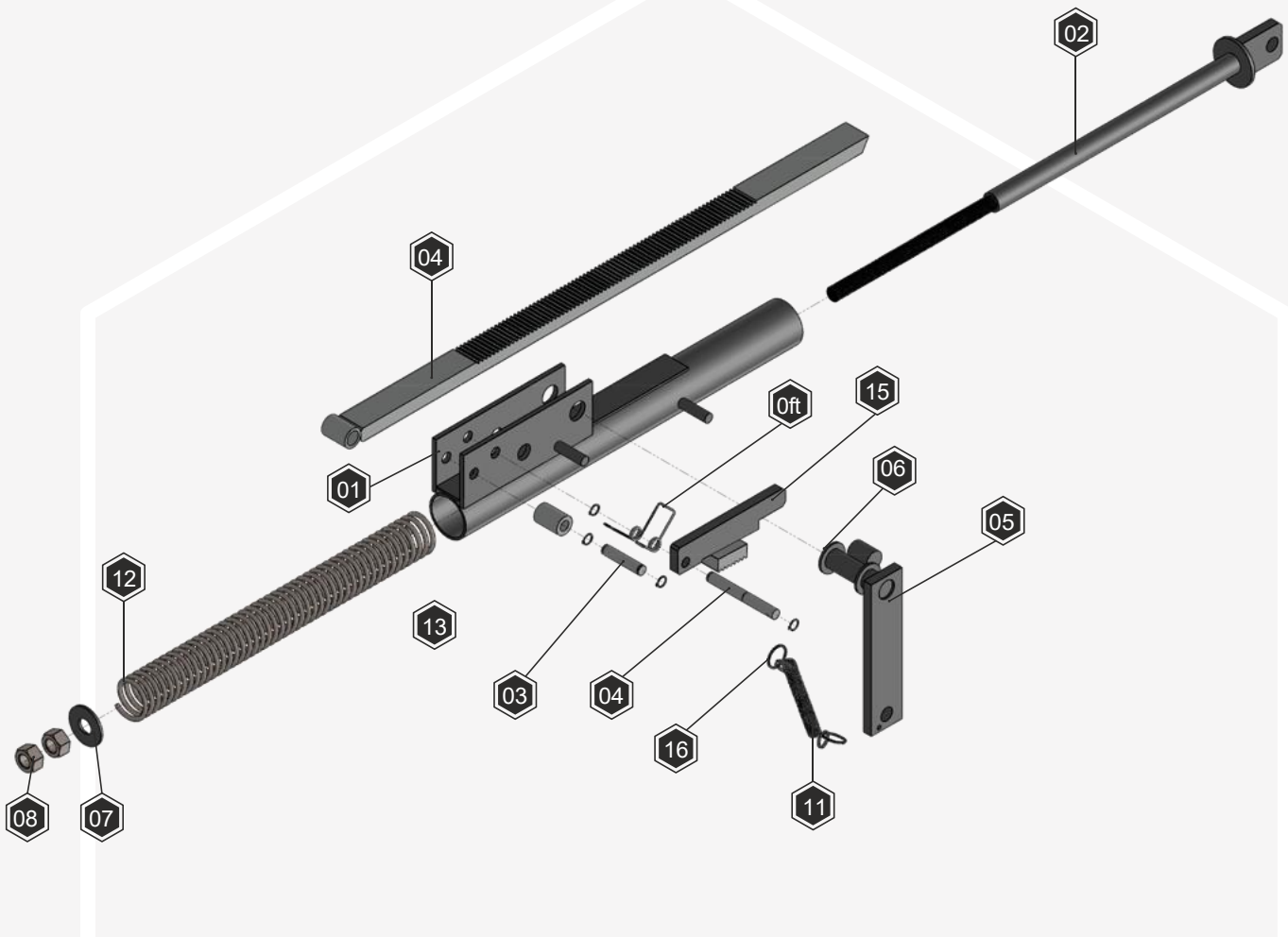

ELEMENT  
NUMBER

NAME

QUANTITY

CODE

01	Mechanical Tube Assembly	1	RNM-ASSY-FR-01
02	Rod Assembly	1	RNM-ASSY-FR-02
03	Brake Short Bolt	1	RNM-ASSY-FR-03
04	Brake Long Bolt	1	RNM-ASSY-FR-04
05	lever assembly	1	RNM-ASSY-FR-05
06	Special Brake Washer	2	RNM-ASSY-FR-06
07	Type 1 Spring Base	1	RNM-ASSY-FR-07
08	Hexagonal nut 3/4" - 10 NC	2	MPTOR1263
09	Butterfly Spring	4	MPT1016
10	1/2" External Truck Lock	1	MPHS1001
11	Brake Lever Spring	1	MPR1010
12	Brake Compression Spring	1	MPR1015
13	Rack Guide Bushing	1	RNM-ASSY-FR-08
14	Rack Assembly	1	MPTOR1419
15	Toothed Block Assembly	1	RNM-ASSY-FR-09
16	1" Metal Ring	2	MPTOR1394

ITEM	ELEMENT NUMBER	QUANTITY	CODE
01	RM- Roller 3.75IN	1	RNM-ASSY-CR-01
02	RM- Bolt - Fork	2	RNM-ASSY-CR-02
03	RM- Trolley - Cutting	1	RNM-ASSY-CR-03
04	RM- Carriage Pulley Bolt	1	MAQ1013
05	RM- Bearing 5205	4	MPRO1007
06	Lock Truack 25mm External	2	MPHS1003
07	RM- Bearing 6005	2	MPRO1002
08	Lock Truack 1-3/4" Inner	2	MPHS1002
09	Lock Truack 52mm Inner	4	MPHS1004

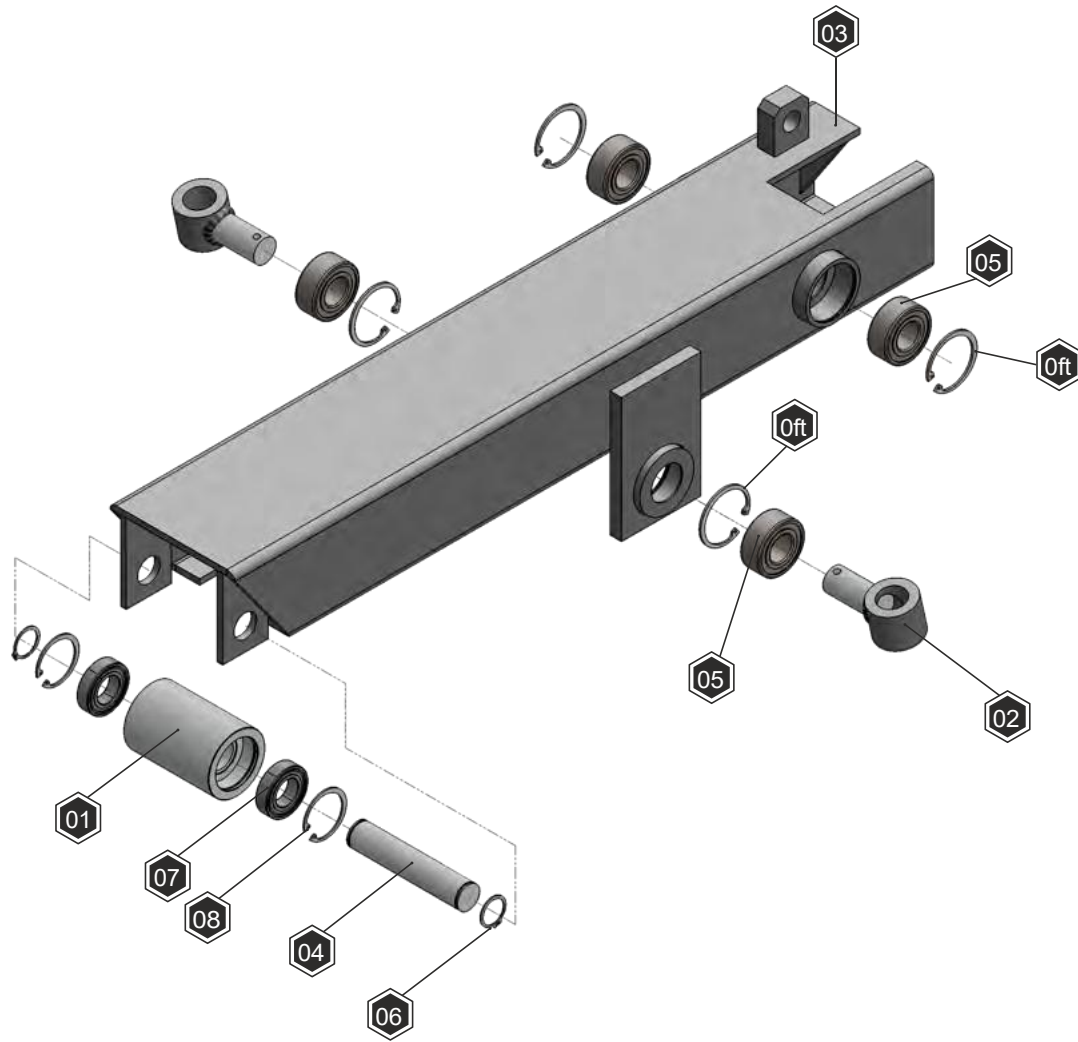

▶ 11.5 SPARE PARTS

MPR1012

TENSION SPRING FOR MAIN RAMP

004



MPR1020

10-INCH LIP THRUST COMPRESSION SPRING

001



MPR1018

TENSION SPRING WITH HOOK FOR LIP LOCK

001



MPR1016

DOUBLE TORSION SPRING

001



MPR1015

COMPRESSION SPRING FOR BACK LOCK

001



MPR1010

TENSION SPRING WITH BRAKE LOCK HOOKS

001



MPR105

TENSION SPRING 4-1/2" MECHANICAL RAMP

001



CODE	DESCRIPTION	QYT	PICTURE
------	-------------	-----	---------

CAL1129

WARNING DECAL

004



CAL1122

DANGER DECAL

001



CAL1132

RAMP SAFETY DECAL

001



CAL1135

DECAL FORM OF OPERATION

001



CAL1134

DECAL FORM OF OPERATION

001

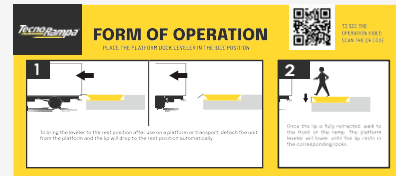

CAL1130

SECURITY BAR WARNING STICKER

001

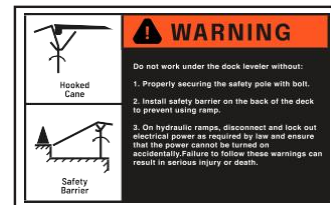

MPR1031

001

▶ 11.7 VISUAL AID MECHANICAL PLATFORM RAMP DECALS

LABELS LEFT SIDE



# LABELS RIGHT SIDE

**TechnoRamp** **FORM OF OPERATION**  
 TROCK 115 (5.0 T) / 120 (5.5 T) / 130 (6.0 T) / 140 (6.5 T) / 150 (7.0 T)



**1**  
 Pushing the handle to the right position allows use as a platform to transport materials from the platform and the lip will stop to the right position automatically.

**2**  
 Once this lip is fully returned back to the right side of the unit, the platform barrier will lower and lift for users on the corresponding side.



**WARNING**  
 Do not elevate from this side.  
 The ramp will be damaged.



**WARNING**  
 This equipment can crush hands if handled with care and common sense only. Only trained and qualified personnel should operate and/or care for this equipment. Keep feet and hands away from points where they can be reached when the equipment is operation.

**DANGER**  
 This equipment can crush hands if handled with care and common sense only. Only trained and qualified personnel should operate and/or care for this equipment. Keep feet and hands away from points where they can be reached when the equipment is operation.

**WARNING**  
 Do not work under the dock leveler without:

1. Properly securing the safety pole with bolt.
2. Install safety barrier on the back of the deck to prevent using ramp.
3. On hydraulic ramps, disconnect and lock out electrical power as required by law and ensure that the power cannot be turned on accidentally. Failure to follow these warnings can result in serious injury or death.



Hooked Cane



Safety Barrier



  
  
**N&H**  
**ACCESOS INDUSTRIALES**

**LODEM**  
LABORATORY OF EQUIPMENT MANUFACTURERS



EMPRESA CERTIFICADA



N&H ACCESOS INDUSTRIALES  
OTE 16A 19, CARLOS HANK GONZALEZ, 56510  
ESTADO DE MÉXICO  
55 1306 8592

[hugo.cruz@nyhaccesosindustriales.com](mailto:hugo.cruz@nyhaccesosindustriales.com)

---